

HORIZONTAL SPLIT CASING PUMPS
TYPE : UP / UPL / UPH



HORIZONTAL AXIALLY SPLIT CASING PUMPS

Range :

Delivery size upto 1220 mm
Capacity up to 24,000 m³/hr
Head up to 180 meters

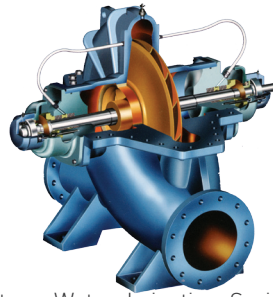

Applications :

Suitable for handling water with slight impurities in Industries, Water Works, Storm Water, Irrigation, Sprinkler Irrigation Fire-fighting, Air Conditioning, Water Circulation, Waste Water Treatment, Processing, Power, Fertilizer, Refinery, Paper, Sugar and Textile Mills, etc.,

Constructional Features :

These are horizontal axially split casing, single stage, double suction, single volute or double volute type pumps with horizontal shaft.

Special Features

Bottom suction branch.

Rotating assembly accessible for inspection or maintenance by removing upper half casing without disturbing suction and delivery piping and motor.

Horizontal execution (standard) or vertical execution (optional)

Vertical pump, direct drive or with universal shaft arrangement.

High hydraulic and overall efficiency due to superior design and manufacturing techniques.

Good suction performance and low NPSH.

Stable characteristics, minimum maintenance required, vibration free performance.

High reliability.

Pump Casing :

Horizontal axially split volute type, suction and discharge nozzles and supporting feet are cast integral with lower half casing.

Impellers :

Double or single suction type accurately balanced. In case of double suction impellers, the hydraulic thrust is balanced automatically because of pressure equalization on both sides of the impeller.

Shaft :

The high tensile steel shaft accurately machined and ground is supported by antifriction bearings that take the residual axial thrust and prevent axial float or radial run out. The shaft is protected by shaft sleeve from wear in stuffing box area.

Stuffing Box :

Can be sealed by gland packing or by mechanical seal and is suitable for liquids having temperature upto 90°C.

Bearings :

Grease Lubricated deep groove ball / roller bearings are provided. Large pumps can be provided with Oil Lubricated / Oil ring bearings.

Direction of Rotation :

Standard : Anticlockwise (ACW) when viewed from driving end.

Optional : Clockwise (CW) when viewed from driving end.

Drive :

Suitable for coupling with electric motors, engines or steam turbines either directly or through belt drives, gear boxes etc.

Flanges :

Standard : Drilled to BS : 10 Table D/E/F or BS-4504, Table PN 16 plain face depending upon model.

Optional : DIN / ASA with suitable pressure rating depending upon model.



UP (METRIC) PUMP

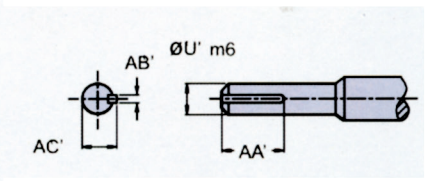
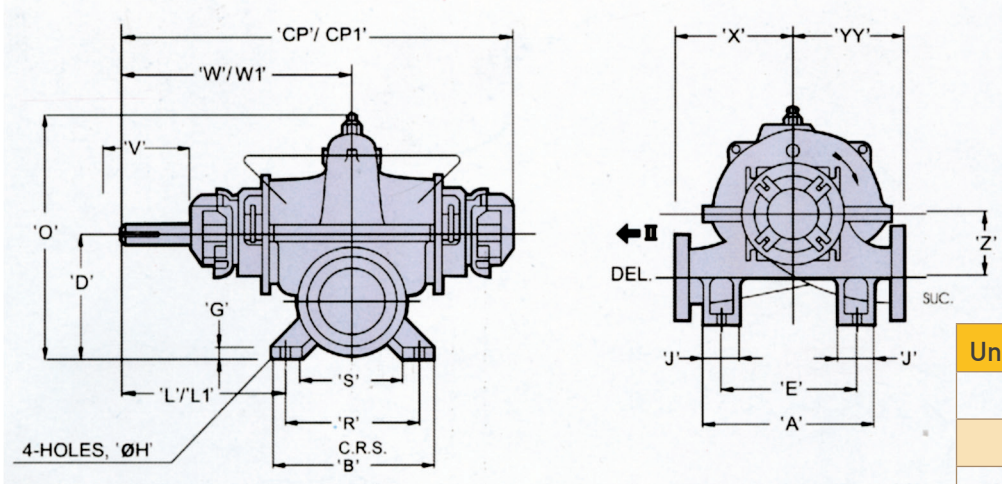

Unit No	'U' m6	'AA'	'AB'	'AC'
0	24	44	8	27
I	25	50	8	28
IE	32	60	10	35
II	42	87	12	45
III	55	85	16	59

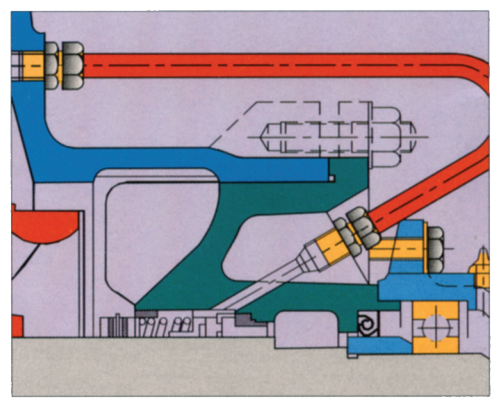
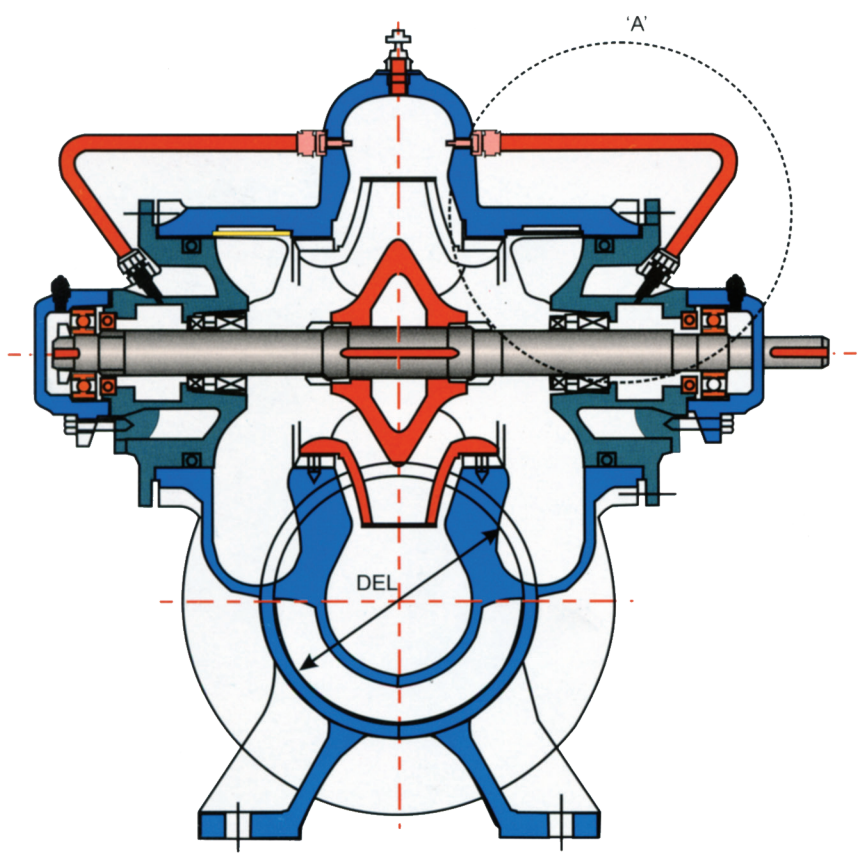

DETAILS AT - A

DIMENSIONS

PUMP TYPE	FOR SOFT PACKED																			FOR MECHANICAL SEAL					
	Module No.	SUC	DEL	'A'	'B'	'D'	'E'	'G'	'H'	'J'	'O'	'R'	'S'	'V'	'W'	'X'	'Z'	'CP'	'YY'	'L'	'Wt' Kg.	'W1'	'CP1'	'L1'	'Wt' Kg.
UP 50/30A	0	65	50	300	210	240	230	15	14	70	442	170	90	48	304	225	140	548	275	219	80	276	506	191	72
UP 50/30B		65	50	300	210	240	230	15	14	70	442	170	90	48	304	225	140	548	275	219	80	276	506	191	72
UP 65/24		80	65	300	210	240	230	18	14	70	440	170	90	50	306.5	210	130	565	280	221.5	84	306.5	565	221.5	84
UP 80/24		100	80	300	210	250	230	18	14	70	450	170	90	50	306.5	230	130	565	270	221.5	95	306.5	565	221.5	95
UP 65/38	I	80	65	400	240	300	300	25	23	100	575	190	100	55	375	275	175	696	315	280	164	292	530	197	150
UP 65/38M		80	65	400	240	300	300	25	23	100	575	190	100	55	375	275	175	696	315	280	164	292	530	197	150
UP 80/30		125	80	330	280	310	340	25	23	100	585	220	130	56	375	240	170	696	320	265	130	292	530	182	146
UP 80/38		100	80	440	280	310	340	25	23	100	585	220	130	56	375	285	175	696	340	265	158	292	530	182	146
UP 100/24		150	100	260	280	330	160	20	23	100	553	220	130	56	375	210	170	696	310	265	158	292	530	182	146
UP 100/25		150	100	300	280	310	200	25	23	100	553	220	130	56	375	230	190	696	310	265	137	292	530	182	146
UP 125/24		150	125	310	330	330	210	25	23	100	560	270	180	56	394	235	180	734	350	259	180	316	578	181	170
UP 125/30A		150	125	370	330	330	270	25	23	100	580	270	180	56	394	245	175	734	335	259	182	316	578	181	172
UP 125/30B		150	125	370	330	330	270	25	23	100	580	270	180	56	394	245	175	734	335	259	182	316	578	181	172
UP 100-35	IE	150	100	400	300	360	300	20	23	100	630	240	140	75	413	260	205	753	340	293	177	413	753	293	177
UP 100/38	II	150	100	440	330	360	340	25	23	100	660	270	180	90	480	300	210	872	400	345	240	378	668	243	218
UP 150/26N		200	150	500	370	385	400	25	23	100	635	300	220	90	480	355	195	897	380	330	262	480	897	330	262
UP 150/30		200	150	370	370	415	270	25	23	100	695	310	220	90	480	270	235	872	365	325	253	378	668	223	236
UP 150/30AN		200	150	500	370	385	400	25	23	100	655	300	220	90	480	355	195	897	380	330	270	480	897	330	270
UP 150/38A		200	150	450	370	390	350	25	23	100	680	310	220	90	480	310	210	872	410	325	286	378	668	223	271
UP 150/38B		200	150	450	370	390	350	25	23	100	680	310	220	90	480	310	210	872	410	325	286	378	668	223	271
UP 150/38BC		200	150	450	370	390	350	25	23	100	680	310	220	90	480	310	210	872	410	325	286	378	693	223	271
UP 150/45		200	150	450	370	450	350	25	23	100	780	310	220	90	480	355	269	872	430	325	308	378	693	223	291
UP 200/30		250	200	420	470	495	320	25	23	100	810	410	320	90	512	300	285	936	450	307	372	410	732	205	356
UP 200/38		200	200	520	470	400	420	25	23	100	720	410	320	90	512	350	225	936	480	307	350	410	732	205	331
UP 250/30		250	250	520	470	460	420	25	23	100	775	410	320	90	512	360	250	936	430	307	348	410	732	205	332
UP 250/38		250	250	570	490	475	470	25	23	100	850	410	320	90	512	420	265	936	540	307	420	410	732	205	404
UP 150/53	III	200	150	750	400	500	600	25	27	150	890	320	200	110	592	450	320	1077	500	432	588	592	1077	432	588
UP 200/42		250	200	680	400	500	530	28	27	150	840	320	200	110	592	450	270	1077	550	432	560	592	1077	432	560
UP 200/56		250	200	710	500	600	560	30	27	150	1070	400	200	110	592	450	372	1077	550	392	740	592	1077	392	740

NOTES :

- 1) All dimensions are in mm.
- 2) Flanges Drilled to BS 4504 PN 16 (FF)
- 3) For mechanical seal version other dimensions remain the same.
- 4) Standard direction of rotation anti-clockwise viewed from driving end.



UP / UPH / UPL PUMP

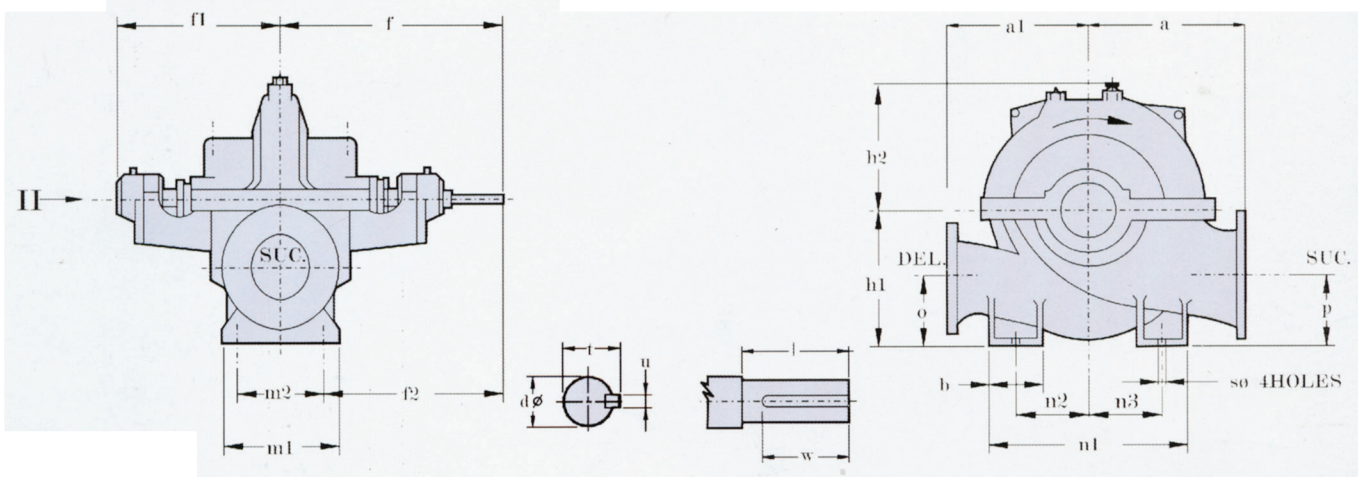

DIMENSIONS

PUMP TYPE MODEL	SUC	DEL	PUMP MOUNTING DIMENSIONS																SHAFT END					WT
	∅	∅	a	a1	f	f1	f2	h1	h2	b	m1	m2	n1	n2	n3	s∅	o	p	d∅	l	t	u	w	KG
6UP 4F/4F (L)	200	150	445	405	512	446	283.5	445	370	152	533	457	533	190.5	190.5	1"	142	176	42	85	46	12	75	514
6UP 4FB	200	150	500	405	462	456	302	490	368	150	400	320	635	195	290	25	180	180	42	85	46	12	75	575
6UP 4FB*	200	150	500	405	512	406	352	490	368	150	400	320	635	195	290	25	180	180	42	85	46	12	75	485
8UPH1	250	200	425	325	517	467	372	470	375	140	350	290	540	150	250	23	213	213	42	67	45	12	62	822
8UPH6M	250	200	550	525	700	618	500	595	455	160	480	400	715	265	290	27	225	225	65	100	69	18	94	1170
10UPH 6	300	250	650	600	820	690	600	620	490	200	540	440	850	300	350	27	275	275	80	150	85.5	22	142	1600
14UPH4 / 4M1	400	350	850	650	1010	875	730	900	640	240	660	560	980	370	370	33	330	330	95	160	102	25	128	2800
14UPH 6	400	350	850	700	950	890	650	800	550	200	670	600	1150	400	550	27	360	360	95	180	102	25	170	2900

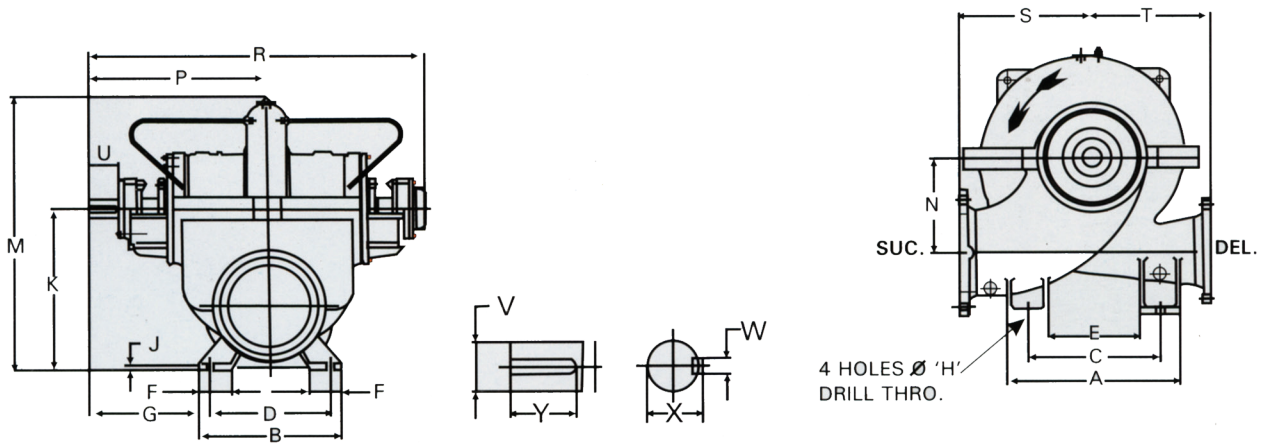

UP (METRIC) PUMP

PUMP TYPE	SUC	DEL	A	B	C	D	E	F	G	H	J	K	M	N	P	R	S	T	U	V	W	X	Y	WT KG
UP 250/57	300	250	650	520	500	440	350	120	418	27	25	600	1025	360	638	1218	500	450	100	68	20	72.5	72	1040
UP 300/46	350	300	710	500	560	400	410	150	438	27	25	630	1065	350	638	1218	575	475	100	68	20	72.5	72	1035
UP 300/57	350	300	890	560	750	500	590	120	460	27	35	650	1120	365	710	1300	650	550	135	80	22	85	131	1152
UP 350/54	400	350	850	600	700	500	450	130	428	27	25	740	1230	420	678	1298	725	225	100	68	20	72.5	72	1404
UP 350/66	400	350	950	600	750	500	550	120	525	27	25	760	1300	455	775	14155	725	575	150	80	22	85	146	1568
UP 400/46	400	400	850	600	700	500	450	110	445	27	25	720	1260	420	695	1326	700	550	90	55	16	59	78	990

* For clockwise Direction of Rotation.



UP (METRIC) PUMP

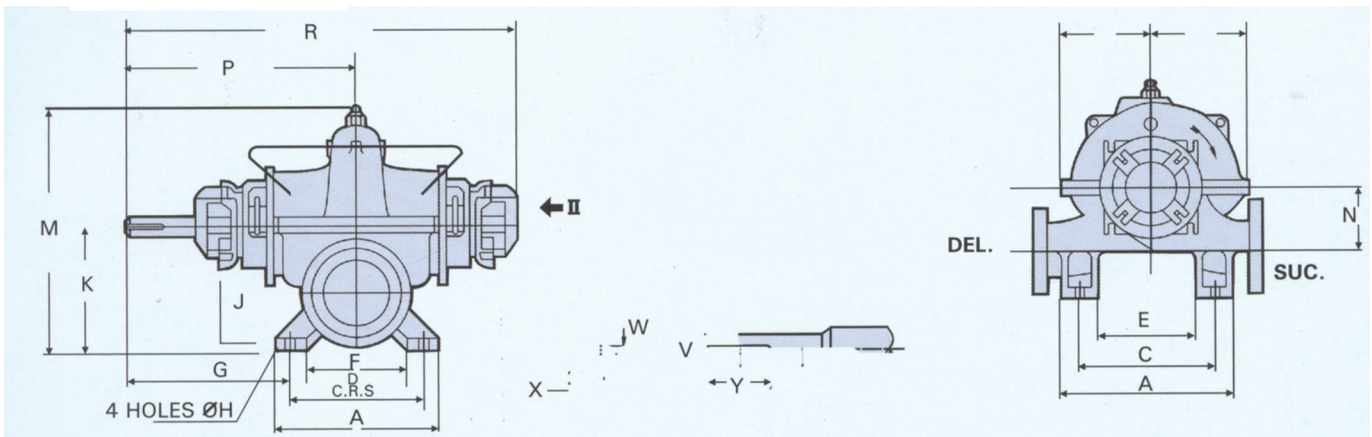

PUMP TYPE	SUC	DEL	A	B	C	D	E	F	G	H	J	K	M	N	P	R	S	T	U	V	W	X	Y	WT KG
UP 200/56	250	200	710	500	560	400	410	450	392	27	30	600	1070	372	592	1077	550	450	110	55	16	59	85	740
UP 250/33	300	250	540	400	410	320	300	100	352	23	25	510	865	275	512	936	450	340	90	42	12	45	87	445
UP 250/46	300	250	650	520	500	440	350	120	392	27	25	575	965	320	612	1117	525	425	109	55	16	59	85	700
UP 300/34	350	300	710	500	560	400	410	150	383	27	25	600	1000	320	593	1102	550	450	85	42	12	45	87	678
UP 300/39	350	300	710	500	560	400	410	150	452	27	25	600	995	320	652	1197	525	450	109	55	16	59	85	755

Material Standards

MATERIAL	EQUIVALENT INTERNATIONAL STANDARDS		
	IS	BS	ASTM
Cast Iron (C)	IS 210 (1978) Gr. FG 260	BSEN 1561-EN-GJL 250	ASTM-A 48 CL 35
SG Iron (SGI)	IS 1865 (1974) Gr. SG 500/7	BS 2789 SNG 500/7	ASTM - A 536 60-40-18 & 65 45-12
Austenitic Cast	IS 2749 Gr. AFG Ni 15	BS 3468 Aus 101 Gr. B	ASTM - A 436 Type 1
Iron (ACI)	Cu 6 Cr 3		
Carbon Steel (CS)	IS 1570 Gr. 40CC8	BS 970 080M 40	ASTM - A 107 Gr. 1040
CF8M (St. St.)	IS 3444 Gr. 9	S 1632 Gr. B	ASTM - A 351 Gr. CF8M
AISI 316 (St. St.)	IS 1570 Gr. 05 Cr 18 Ni 11 Mo 3	BS 970 316 S16	ASTM - A 276 Type 316
AISI 304 (St. St.)		BS 970 - 304 S 15	ASTM - A 276 Type 304
AISI 410 (St. St.)		BS 970 410 S 21	ASTM - A 276 Type 410
Bronze	IS 318 Gr. LTB2	BSEN 1982 - CC 491K	ASTM - B62, B145 Alloy 4A
Phosphor Bronze (Ph. Br.)	IS 28 Gr. 1		
Zinc Free Bronze (ZFB)		BSEN 1982 - CC 480K	
Cast Steel		BS 1504-101A	ASTM-A 21674 d Gr. WCB

Material of construction

Casing Half Upper	CI	CI	CI	CI	CI	CI
Casing Half Lower	CI	CI	CI	CI	CI	CI
Impeller	CI	Bronze	Bronze	Bronze	CI	CF 8M
Wear Ring	CI	Bronze	CI	Bronze	CI	CI
Shaft	40C8/SS410	40C8/SS 410	40C8/SS410	40C8/SS410	40C8	40C8
Shaft Sleeve	CI	Bronze	CI	SS 410 H	SS 410H	SS 410H

* For clockwise Direction of Rotation.



UP / UPH / UPL PUMP

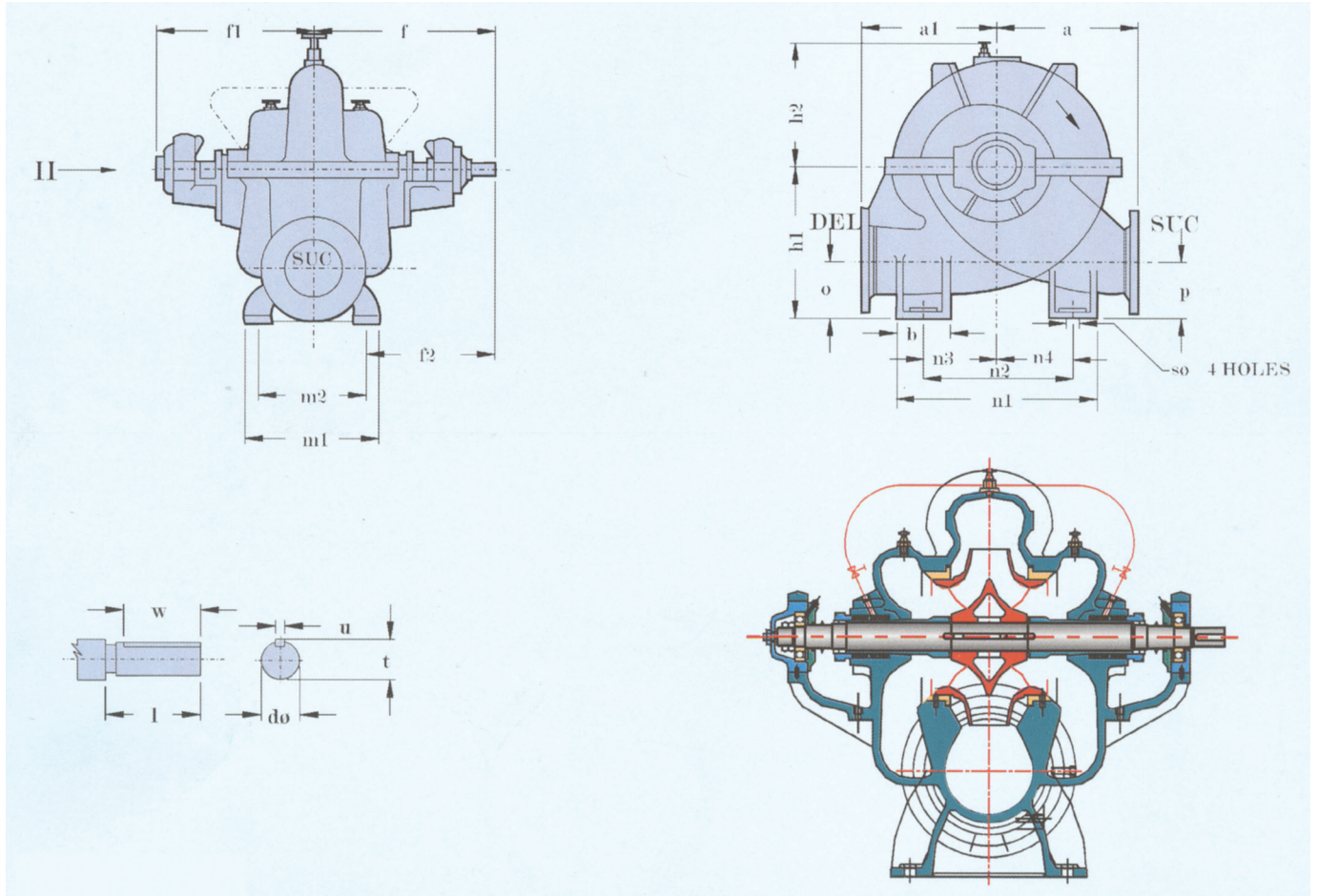

DIMENSIONS

PUMP TYPE MODEL	SUC DEL		PUMP MOUNTING DIMENSIONS															SHAFT END					WT		
	∅	∅	a	a1	f	f1	f2	h1	h2	o	P	b	m1	m2	n1	n2	n3	n4	s∅	d∅	l	t	u	w	KG
16UPH1/2	450	400	800	670	725	665	425	770	540	330	330	240	720	600	1100	870	370	500	27	68	100	74	20	90	2150
16 UMCS2	450	400	800	670	725	665	425	770	540	330	330	240	720	600	1100	870	370	500	27	68	100	74	20	90	2150
16 UPH3	450	400	850	650	875	745	575	860	565	330	330	240	720	600	1140	900	350	550	27	90	150	97	25	142	2810
UPH550/70(C)	650	550	1000	750	1165	960	715	1150	700	550	550	220	1000	900	1120	900	450	450	27	100	165	106	28	160	4500
20UPH1	600	500	850	700	995	865	615	925	580	430	430	250	900	760	1150	900	375	525	30	90	150	97	25	140	2850
20UPH3 (M1)	600	500	850	650	1007	952	607	950	675	490	490	250	900	800	1100	850	325	525	33	95	150	102	25	130	2950
24UPH3/M	760	610	1219	914	1105	871	623	1168	810	546	546	406	1118	965	1474	1270	635	635	33	100	165	106	28	160	5090
28UPL2	750	700	1235	890	1392	1310	792	1220	845	480	480	300	1400	1200	1710	1510	590	920	42	95	150	102	25	130	7015
30UPH1	750	750	1100	850	1165	980	683	1100	795	512	512	350	1115	965	1350	1150	575	575	33	100	165	108	28	145	4920
36UPH2	900	900	1550	1050	1710	1450	1110	1500	975	610	610	350	1400	1200	2000	1650	575	1075	39	175	250	185	45	240	12675
44UPH1A	1200	1100	1750	1350	1825	1600	825	1800	1230	800	800	400	2200	2000	2400	2000	850	1150	50	125	220	132	32	216	18618
20UPH3M2DV	600	600	1275	1050	1400	11175	950	1200	800	540	540	200	1005	900	1725	1425	825	600	41	115	185	122.4	32	180	4500
36UPH2M1	900	800	1426	960	1600	1350	1000	1429	874	610	610	350	1400	1200	1870	1520	530	990	39	125	220	132	32	216	9000
UPH1050/110	1050	1050	1675	1135	1925	1745	1275	1650	1050	710	710	380	1500	1300	2160	1780	620	1160	42	175	220	185.4	45	188	14000
UPH1200/160	1400	1200	2200	1684	2105	1800	1150	2200	1248	1100	1100	400	2200	2000	2400	2000	750	1050	42	160	275	168	40	240	18000

UP / UPH / UPL PUMP

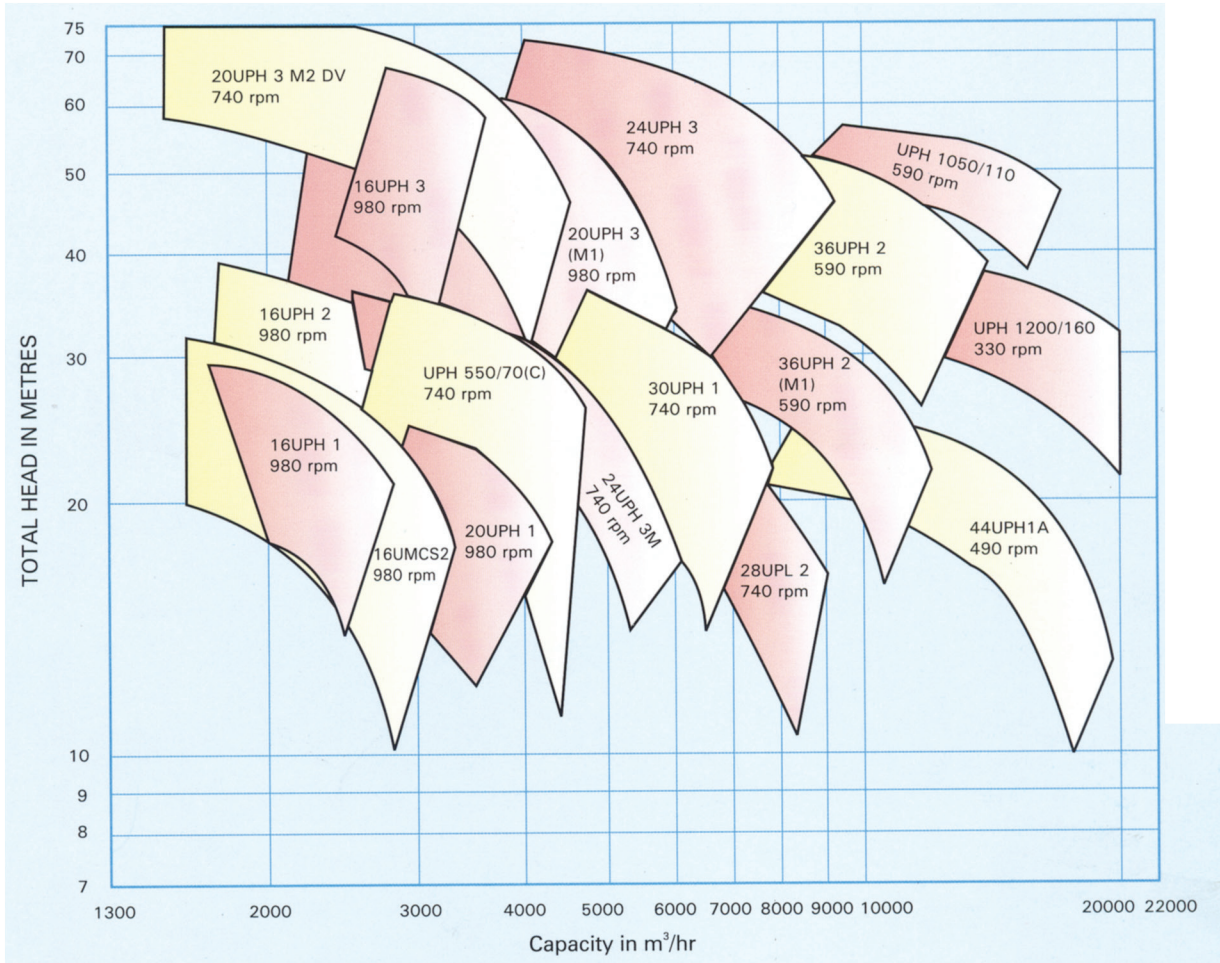

UP PUMPS AT 60 HZ

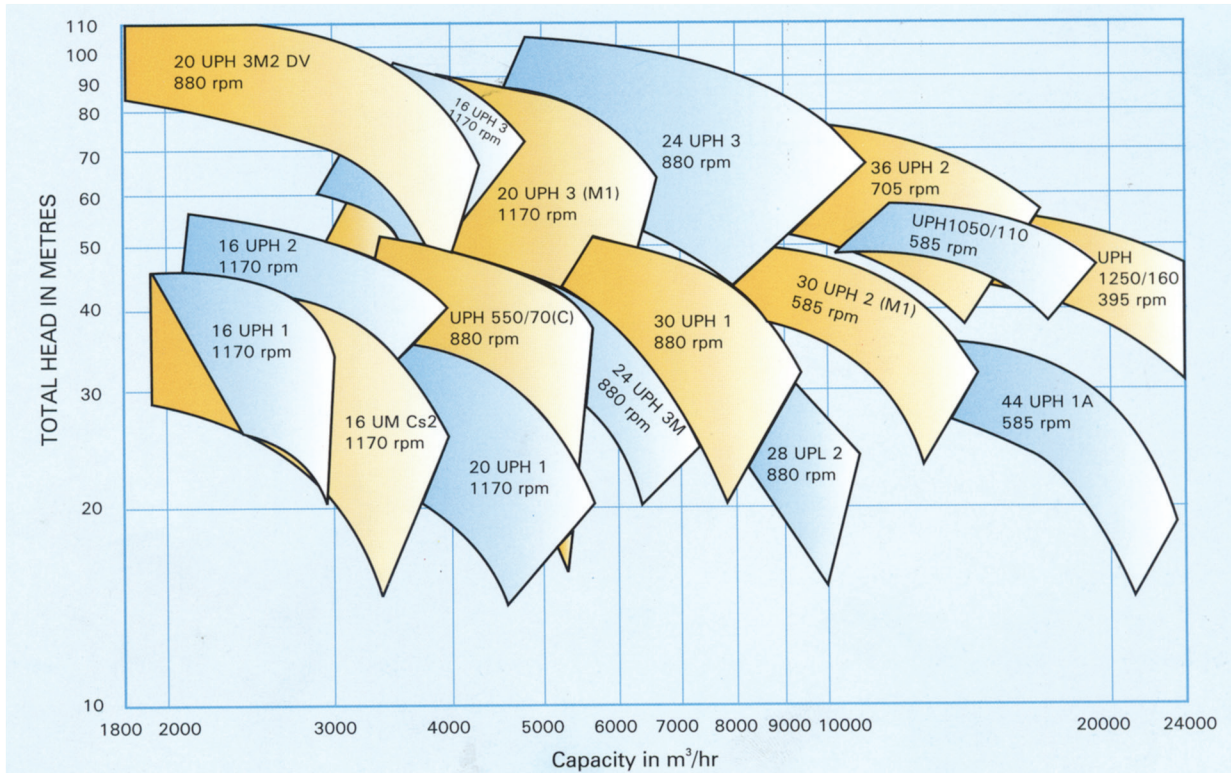

UP (metric) pumps at 1450 rpm - 50 hz

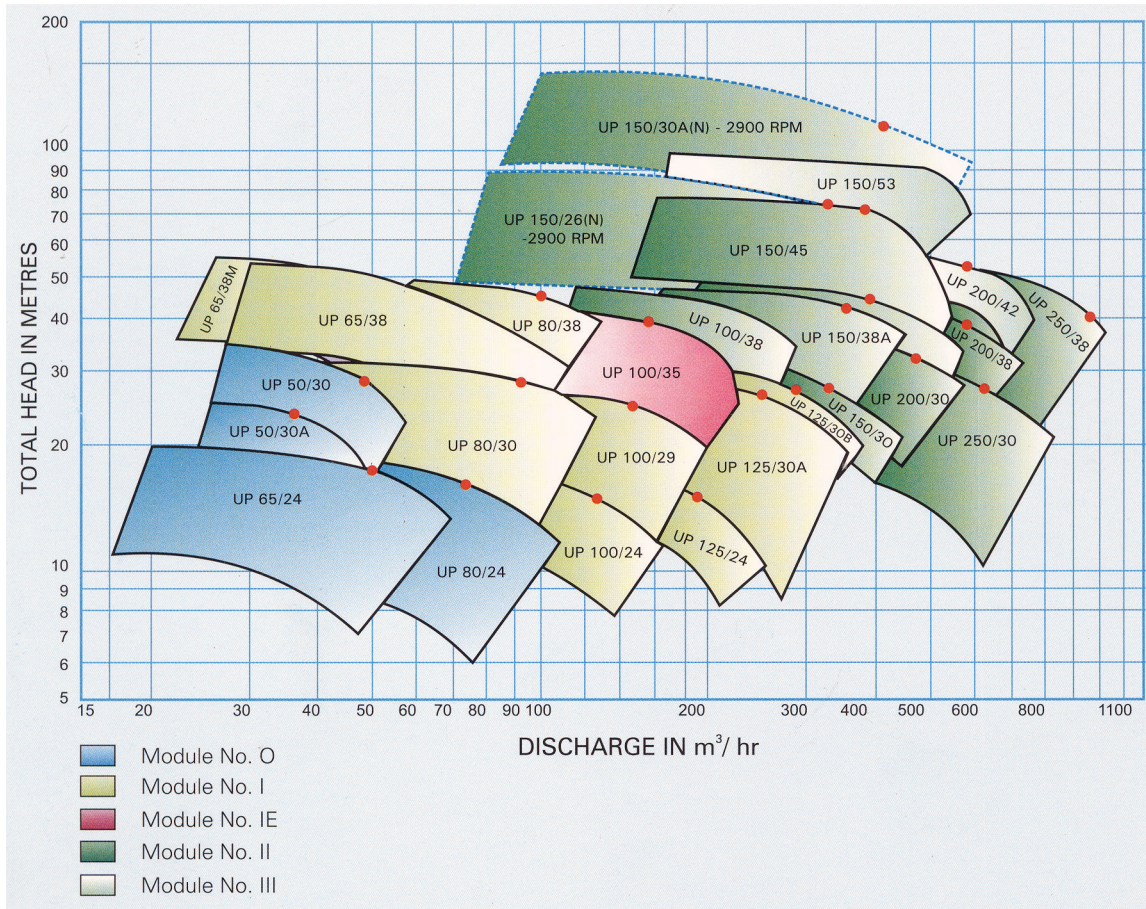

UP pumps at 60 Hz

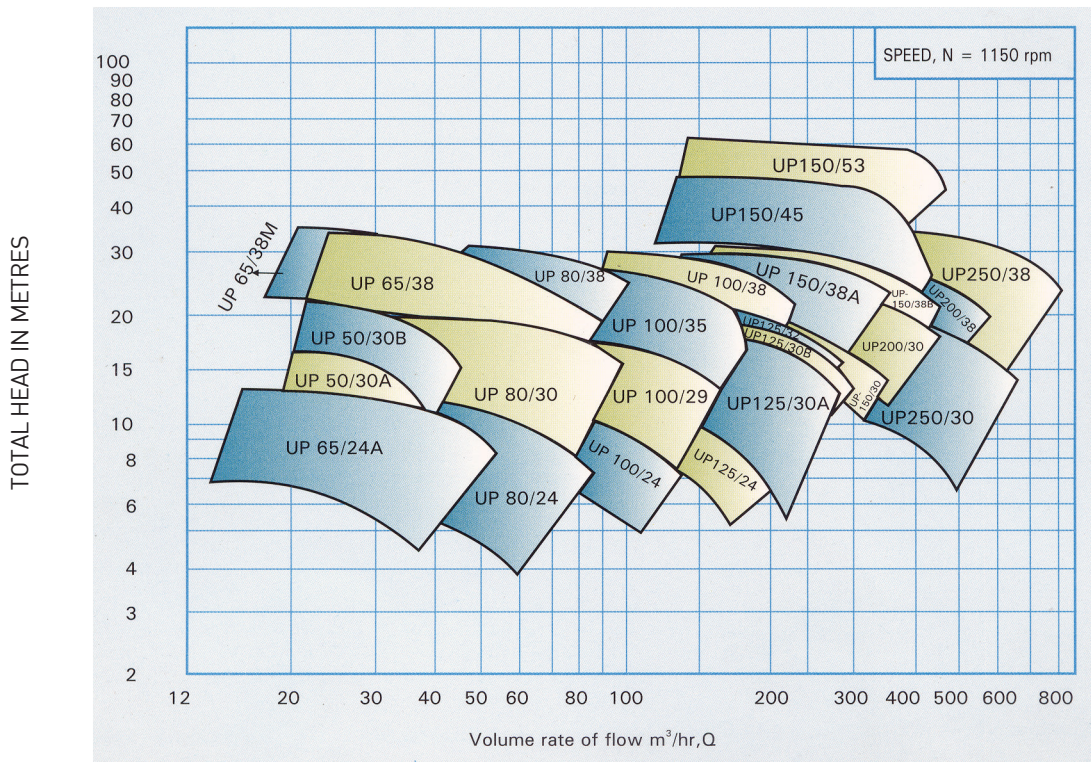

UP / UPL / UPH Pumps at - 50Hz

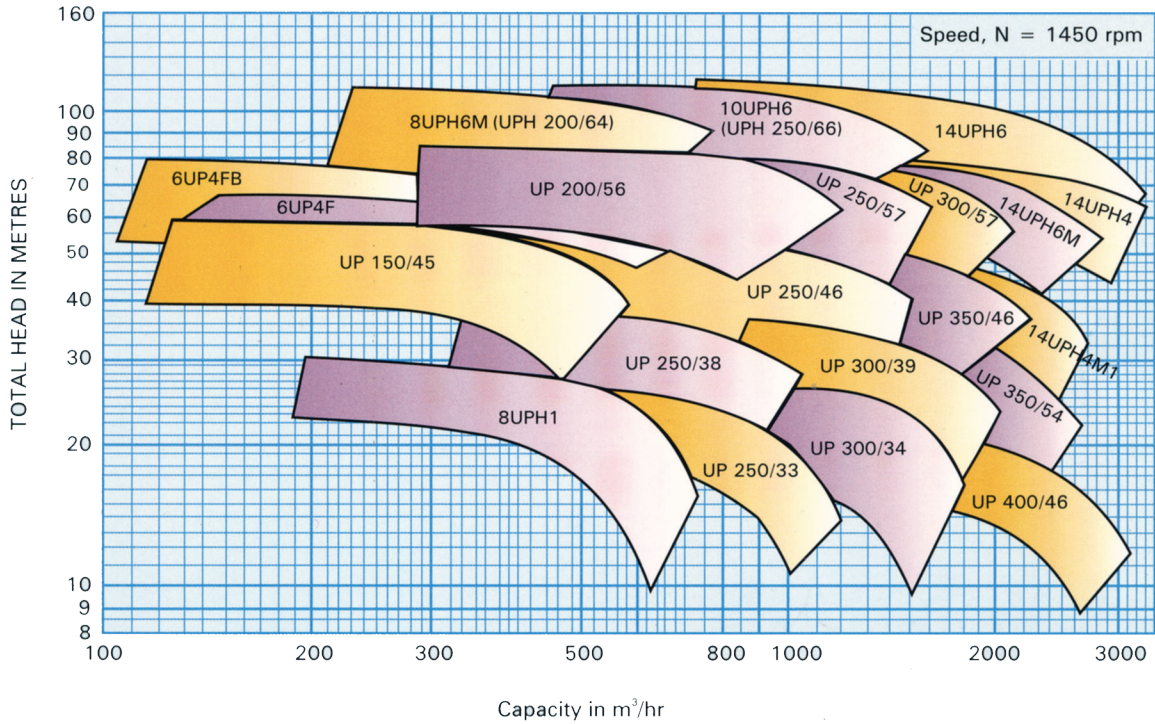

UP Pumps at 60 Hz

