

MULTISTAGE PUMPS
TYPE RKB

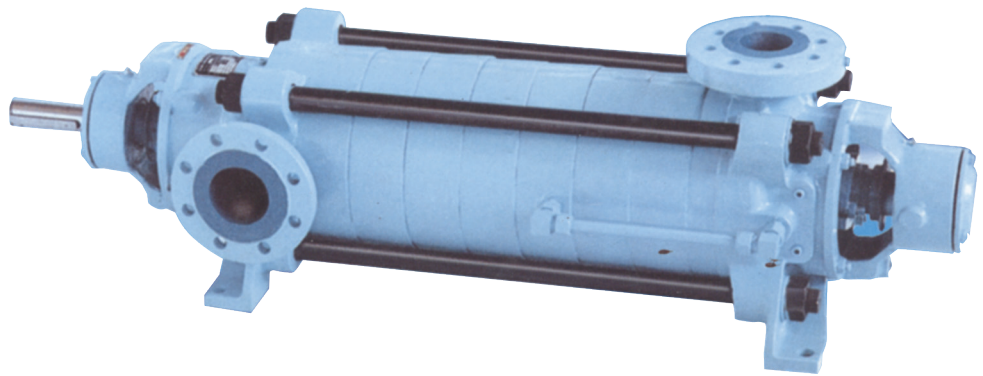

MULTISTAGE PUMPS-TYPE : RKB

Description

Range :

Delivery size upto 250mm
Capacity up to 850 m³/hr
Head up to 850 m

Applications :

Sprinkler irrigation, Fire Fighting, Water supply to high rise buildings, Descaling, Mine dewatering and Boiler feed.

Constructional Features :

This pump consists of a number of ring section diffuser casings bolted between suction and delivery casing. Various models are available to operate at 1450 rpm and 2900 rpm at 50Hz and 1750 rpm and 3500 rpm at 60 Hz power supply frequency.

Casing :

Latest casing techniques ensure smoothness of hydraulic passages resulting in high efficiency and reliability under hazardous conditions. The delivery flange is vertical. The suction flange can be oriented left or right viewed from driving end.

Impeller :

The enclosed impellers of the radial flow type are provided with balancing holes to balance the hydraulic axial thrust. The rotating elements are statically and dynamically balanced.

Shaft :

The high tensile steel shaft accurately machined and ground is supported by antifriction bearings that take the residual axial thrust and prevent axial float or radial run out. The shaft is protected by shaft sleeve from wear in stuffing box area.

Stuffing Box :

The stuffing box can be sealed by gland packing or by mechanical seal with minor modification. While pumping high temperature liquids from 90°C to 140°C, cooling jacket is provided for the stuffing box.

Bearings :

Standard lubrication is grease.
For temperature above 90°C to 140°C - Oil lubrication

Direction of Rotation :

Standard : Clockwise viewed from driving end.
Optional : Anticlockwise viewed from driving end.

Drive :

These pumps are suitable for coupling with electric motors, IC engines or steam turbine either directly or through belt drives.

Flanges :

Standard		Optional
Suction Flange	DIN ND - 10	ASA 125, 150 BS 4504-16/11
Delivery Flange	DIN ND - 40 or ND - 64	ASA 250, 300 or 800 BS 4504-16/11

CUT-SECTIONAL VIEW

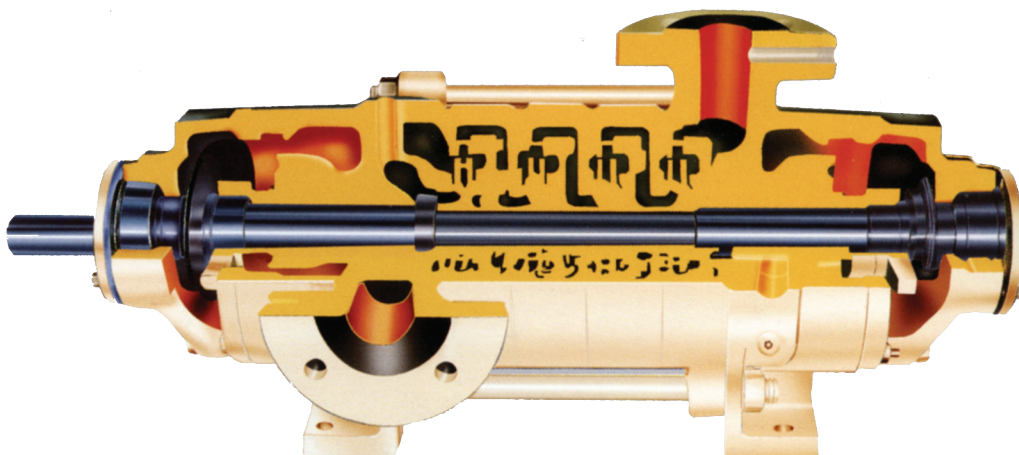

GENERAL DIMENSION

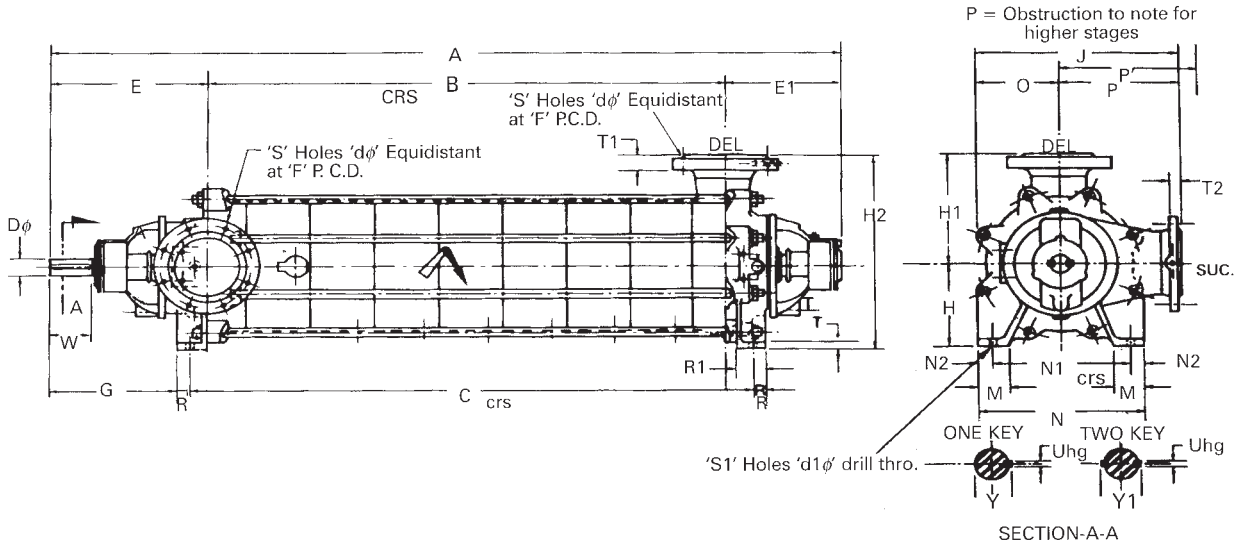

PUMPP MODEL : RKB 32-9E																
c/s.	NO. OF STAGES															
	50 & 60														50	
	140 RPM															
A	582	629	676	723	770	817	864	911	958	1005	1052	1099	1146	1193	1240	
B	117	164	211	258	305	352	399	446	493	540	587	634	681	728	775	
C	207	254	301	348	395	442	489	536	583	630	677	724	771	818	865	
Wt.kgs	53	60	67	73	80	87	93	100	107	113	120	127	134	141	148	
P'																

PUMPP MODEL : RKB 65-24									
c/s.	NO. OF STAGES								
	50 & 60							50	
	140 RPM								
A	1126	1296	1366	1436	1506	1576	1646	1716	
B	195	265	335	405	475	545	615	685	
C	299	349	439	509	579	649	719	789	
Wt.kgs	563	614	665	716	767	818	869		
P'									

PUMPP MODEL : RKB 32/14 H															
c/s.	NO. OF STAGES														
	50 & 60														50
	140 RPM														
A	524	567	610	653	696	739	782	825	868	911	954	997	1040	1083	
B	114	157	200	243	286	329	372	415	458	501	544	587	630	673	
C	264	307	350	393	436	479	522	565	608	651	694	737	780	823	
Wt.kgs	75	84	93	102	111	120	129	138	147	156	165	174	183	192	
P'															

PUMPP MODEL : RKB 100-23E/M																
c/s.	NO. OF STAGES															
	50 & 60														50	
	140 RPM															
A	996	1096	1196	1296	1396	1496	1596	1696	1796	1896						
B	260	360	460	560	660	760	860	960	1060	1160						
C	385	485	585	685	785	885	985	1085	1185	1285						
Wt.kgs	280	320	360	400	440	480	520	560	600	640						
P'																

PUMPP MODEL : RKB 40-12/140/14H																
c/s.	NO. OF STAGES															
	50 & 60														50	
	140 RPM															
A	631.5	686.5	741.5	796.5	851.5	906.5	961.5	1016.5	1071.5	1126.5	1181.5	1236.5	1291.5			
B	137	192	247	302	357	412	467	522	577	632	687	742	797			
C	242	297	352	407	462	517	572	627	682	737	792	847	902			
Wt.kgs	85	95	105	115	125	135	145	155	165	175	185	195	205			
P'	180															

PUMPP MODEL : RKB 125-27 and RKB 125 - 27M																
c/s.	NO. OF STAGES															
	50 & 60														50	
	140 RPM															
A	1089.5	1199.5	1309.5	1419.5	1529.5	1639.5	1749.5	1859.5	1969.5	2079.5	2189.5	2299.5	2409.5			
B	295	405	515	625	735	845	955	1065	1175	1285	1395	1505	1615			
C	401	511	621	731	841	951	1061	1171	1281	1391	1501	1611	1721			
Wt.kgs	319	376	433	490	547	604	661	718	775	832	889	946	1003			
P'																

PUMPP MODEL : RKB 50-15E/L 50/16H																
c/s.	NO. OF STAGES															
	50 & 60														50	
	140 RPM															
A	745	805	865	925	985	1045	1105	1165	1225	1285	1345	1405	1465			
B	160	220	280	340	400	460	520	580	640	700	760	820	880			
C	280	340	400	460	520	580	640	700	760	820	880	940	1000			
Wt.kgs	106.5	118	129.5	141	152.5	164	175.5	187	198.5	210	221.5	233	244.5			
P'	190															

PUMPP MODEL : RKB 125-30																
c/s.	NO. OF STAGES															
	50 & 60														50	
	140 RPM															
A	1165.8	1285.8	1405.8	1525.8	1645.8	1765.8	1885.5	2005.5	2125.8	2245.8	2365.8	2485.5				
B	325	445	565	685	805	925	1045	1165	1285	1405	1525	1645				
C	430	550	670	790	910	1030	1150	1270	1390	1510	1630	1750				
Wt.kgs	410	484	558	632	706	780	854	928	1002	1076	1150	1224				
P'																

PUMPP MODEL : RKB 65-19E/L																
c/s.	NO. OF STAGES															
	50 & 60														50	
	140 RPM															
A	875	951	1027	1103	1179	1255	1331	1407	1483	1559	1635					
B	206	286	358	434	510	586	662	738	814	890	966					
C	341	417	493	569	645	721	797	873	949	1025	1101					
Wt.kgs	155	175	195	215	235	255	275	295	315	335	355					
P'																

PUMPP MODEL : RKB 150-34																
c/s.	NO. OF STAGES															
	50 & 60														50	
	140 RPM															
A	1293	1428	1563	1698	1833	1968	2103	2238	2373	2508	2643					
B	365	500	635	770	905	1040	1175	1310	1445	1580	1715					
C	460	595	730	865	1000	1135	1270	1405	1540	1675	1810					
Wt.kgs	595	697	799	901	1003	1105	1207	1309	1411	1513	1615					
P'																

PUMPP MODEL : RKB 200-37																
c/s.	NO. OF STAGES															
	50 & 60														50	
	140 RPM															
A	1374	1519	1664	1809	1954	2099	2244	2389	2534	2679						
B	405	550	695	840	985	1130	1275	1420	1565	1710						
C	520	665	810	955	1100	1245	1390	1535	1680	1825						
Wt.kgs	753	893	1033	1173	1313	1453	1593	1736	1879	2022						
P'																



MOUNTING DETAILS

Sr. No	Pump Type	PUMP DIMENSIONS																				SHAFT DETAILS					SUC. FLANGES				DEL. FLANGES					
		SUC	DEL	E	G	R	R	H	H1	H2	T THK.	O	P	J	N	N1 CRS	N2	M	No. of Holes S1	d10	U	W	Y	Y1	PN 10				T1	PN 40			PN 64			
																					Do	hg				S	d0	F	T2	THK	S'	d0	F'	S'	d'0	F'
1	RKB 32-9E	40	32	269.5	209.5	15	60	112	140	252	14	105	140	245	210	180	15	60	4	14	25j6	8	60	28	-	4	18	110	18	23	4	15	100	-	-	-
2	RKB 40-12L	50	40	274	218	15	60	25	150	275	14	130	10	280	260	230	15	60	4	14	30k6	8	60	33	-	4	18	125	20	23	4	18	110	-	-	-
3	RKB 50-15E/L	65	50	330	265	20	70	135	180	315	15	140	180	320	280	240	20	65	4	19	35k6	10	80	38	-	4	18	145	20.5	25	4	18	125	-	-	-
4	RKB65-19E/L	80	65	393	326	20	70	180	200	380	15	180	200	380	360	315	22.5	70	4	19	40k6	12	110	43	46	8	18	160	21	33	8	18	145	8	22	160
5	RKB65-24	80	65	565	464	15	100	250	300	550	25	230	300	530	460	360	45	100	4	24	60m6	18	90	64	68	8	18	160	51	33	8	18	145	8	22	160
6	RKB 100-23E	125	100	407	327	30	80	215	275	490	18	205	275	480	420	360	30	80	4	24	46k6	12	110	48.5	52	8	18	210	26	38	8	22	190	8	26	200
7	RKB 125-27	150	125	435.5	379.5	40	100	250	315	565	25	245	315	560	490	400	45	100	4	24	50k6	14	110	53.5	57	8	22	240	28	45	8	26	220	8	30	240
8	RKB 125-30	150	125	453.8	404.9	40	100	280	350	630	25	250	350	600	530	440	45	100	4	26	55m6	16	110	59	63	8	22	240	28	45	8	26	220	8	30	240
9	RKB 150-34	200	150	511.5	476.5	40	100	300	400	70	25	278	400	678	550	460	45	100	4	26	60m6	18	140	64	68	8	22	295	30	55	26	250	8	33	280	
10	RKB200-37	250	200	537	497	40	110	350	500	850	28	320	500	820	630	550	40	110	4	26	65m6	18	140	69	73	12	22	350	32	54	12	30	320	12	36	345

ORIENTATION / ROTATION

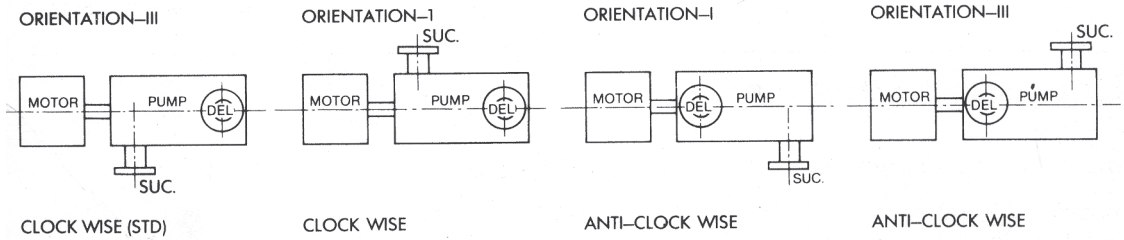

MATERIAL OF CONSTRUCTION

Casing	CI/SGI	CI/SGI	CI/SGI	CI/SGI	CI/SGI	Cast Steel	CI/SGI	St. Steel CF8M
Diffuser	CI	CI/ZFB	CI	CI	CI	Cast Steel	CI	St. Steel CF8M
Impeller	CI/ACI	Bronze/ZFB	Ph. Br.	CI	Cast Steel	Cast Steel	St. St. CF8M	St. St. CF8M
Wear Ring	CI/ACI	Bronze	Ph. Br.	CI	AISI 410H	AISI 410H	St. St. CF8M	St. St. CF8M
Shaft	CS/St. St.	CS/St. St.	CS/St. St.	CS/St. St.	CS/St. St.	CS/St. St.	CS/St. St.	St. St.
Shaft Sleeve	AISI St. St.	AISI St. St.	AISI St. St.	AISI St. St.	AISI St. St.	AISI St. St.	AISI St. St.	AISI St. St.
Lanterm Ring	CI/St. St.	Bronze	Ph. Br.	CI	CS	CS	AISI 316	AISI 316
Gland	CI	CI	CI	CI	CI	Cast Steel	CI	St. St.

MATERIAL STANDARDS

Material	IS	BS	ASTM
Cast Iron (CI)	IS 210 (1978) Gr. FG 260	B.S.E.N. 1561-EN-GJL 250	ASTM-A48 CL 35
S. G. Iron (SGI)	IS 1865 (1974) Gr. SG 500/7	B.S. 2789 SNG 500/7	ASTM-A 536 60-40-18 & 65-45-12
Austenitic Cast	IS 2749 Gr. AFG Ni 15	B.S. 3468 AUS 101 Gr. B	ASTM-A 436 Type 1
Iron (ACI)	Cu 6 Cr 3		
Carbon Steel (CS)	IS 1570 Gr. 40CC 8	B.S. 970 080 M 40	ASTM-A 107 Gr. 1040
CF8M	IS 3444 Gr. 9	B.S. 1632 Gr. b	ASTM-A 351 Gr. CF8M
AISI 316 (St. St.)	IS 1570 Gr. 05 Cr 18 Ni 11 Mo 3	B.S. 970 316 S16	ASTM-A 276 Type 316
AISI 304 (St. St.)		B.S. 970 304 S 15	ASTM-A 276 Type 304
AISI 410 (St. St.)		B.S. 970 410 S 21	ASTM-A 276 Type 410
Bronze	IS 318 Gr. LTB2	B.S.E.N. 1982 - CC 491 K	ASTM-B62, B145 Alloy 4A
Phosphor Bronze (Ph. Br.)	IS 28 Gr. 1		
Zinc Free Bronze (ZFB)			
Cast Steel		BS 1504-101A	ASTM-A 21674 d Gr. WCB

CROSS SECTIONAL VIEW

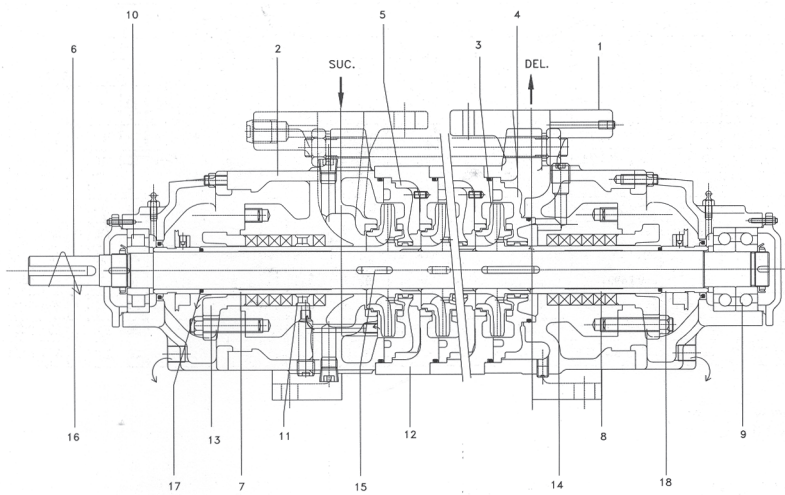

- 1 Delivery Casing
- 2 Suction Casing
- 3 Enclosed Impeller
- 4 Diffuser
- 5 Diffuser with guide vane
- 6 Pump shaft
- 7,8 Shaft Sleeve
- 9 Pair of angular contact ball bearing (NDE)
- 10 Roller Bearing (DE)
- 11 Lantern Ring
- 12 Stage Casing
- 13 Gland
- 14 Gland Packing
- 15 Impeller Key
- 16 Key for Coupling
- 17 'O' Ring
- 18 Distance Sleeve

ALTERNATIVES AVAILABLE

Pump in vertical configuration

Pumps available in vertical execution complete with motor-stool/driving unit. Rotation anticlockwise seen from top.

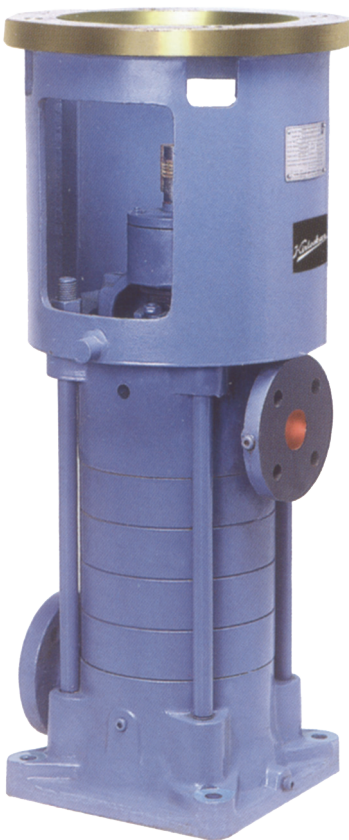

Low NPSH Pumps

Model : RKB 250-46 DK
 First stage impeller : Double Suction
 Subsequent stages Single Suction

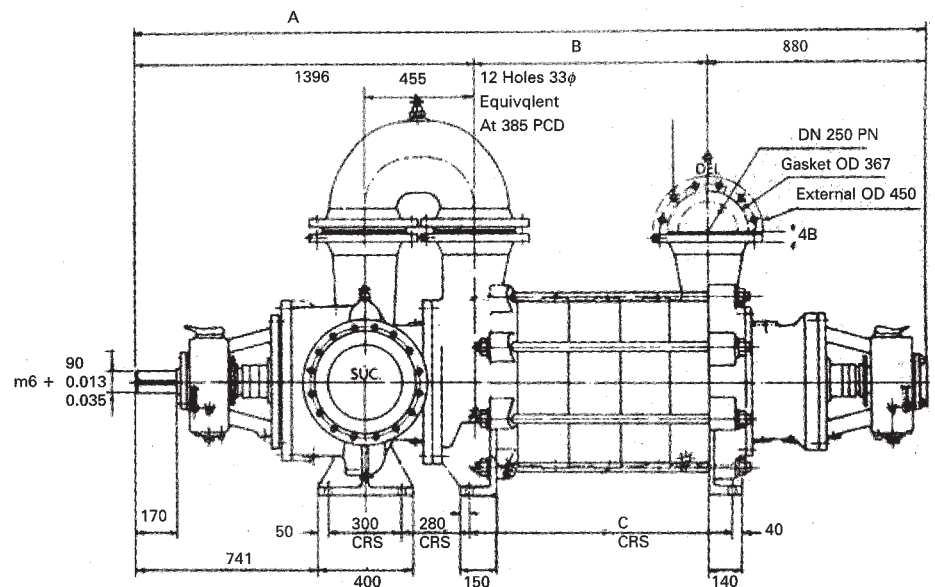

DIMENSIONS	NO. OF STAGES			
	2	3	4	5
A	-	2811	3019	3227
B	-	535	743	951
C	-	660	868	1076
WEIGHT KG		3270	3635	4000

OUTLINE DRAWING OF RKB MULTI-OUTLET PUMPS

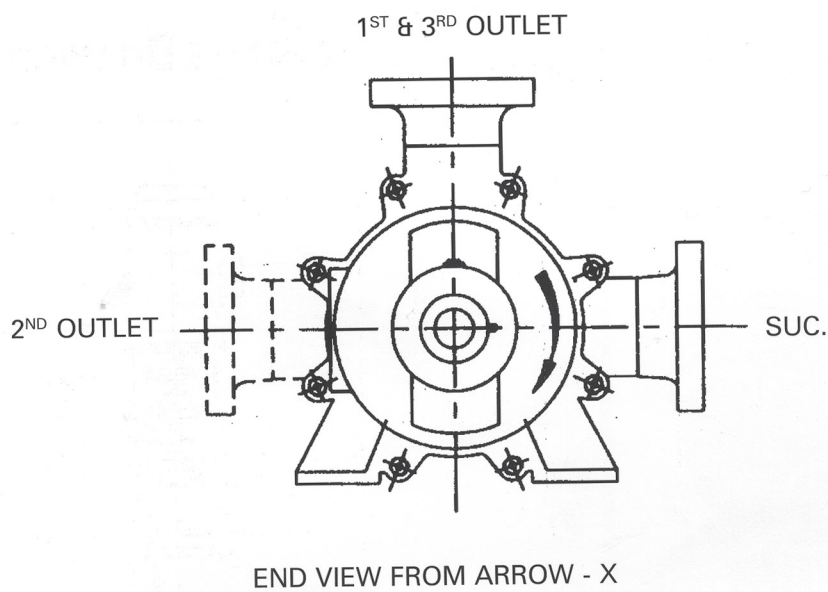
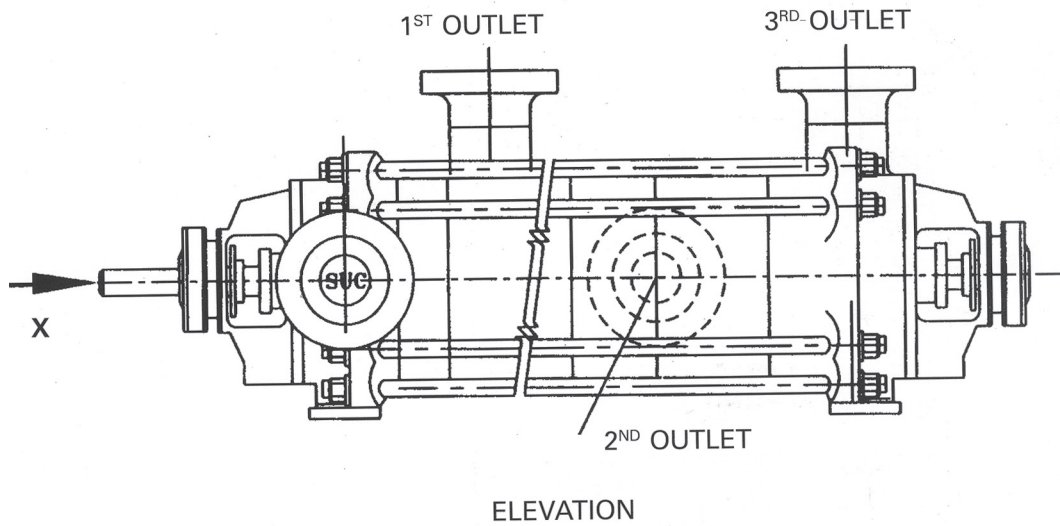

RKB Multioutlet arrangement is normally used when capacity is fixed and total head changes time to time, without disturbing the pump's internals. Available with option of two or three outlets depending upon the requirement.

OUTLINE DRAWING OF RKBCV PUMPS

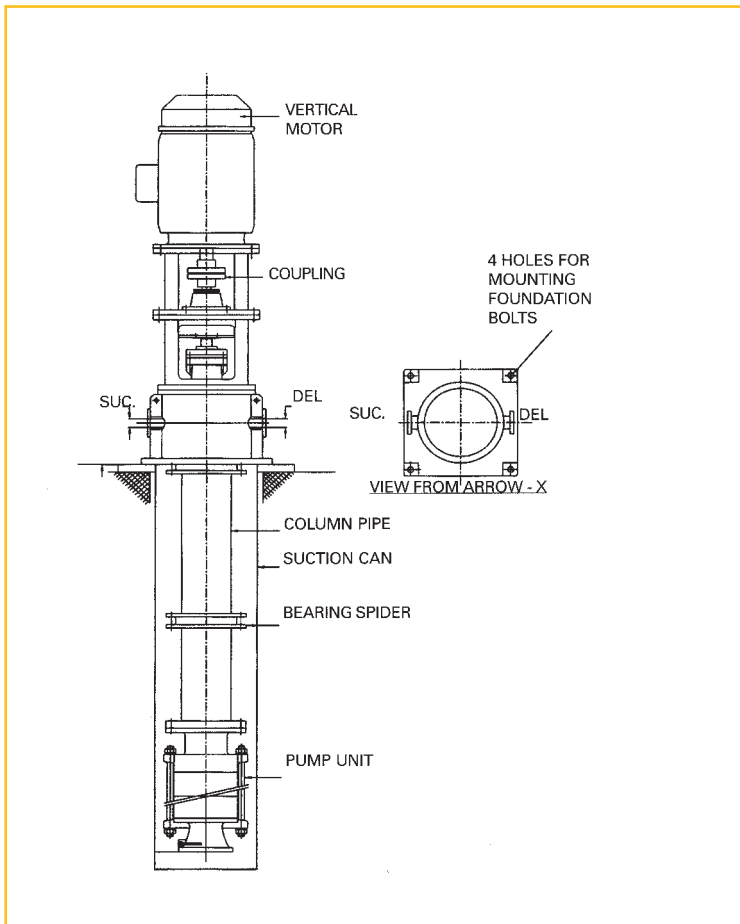

Canned pump construction used for low NPSHA conditions in condensate extraction application under vacuum. All RKB models can be made available with canned design.

OUTLINE DRAWING OF RKBS PUMPS

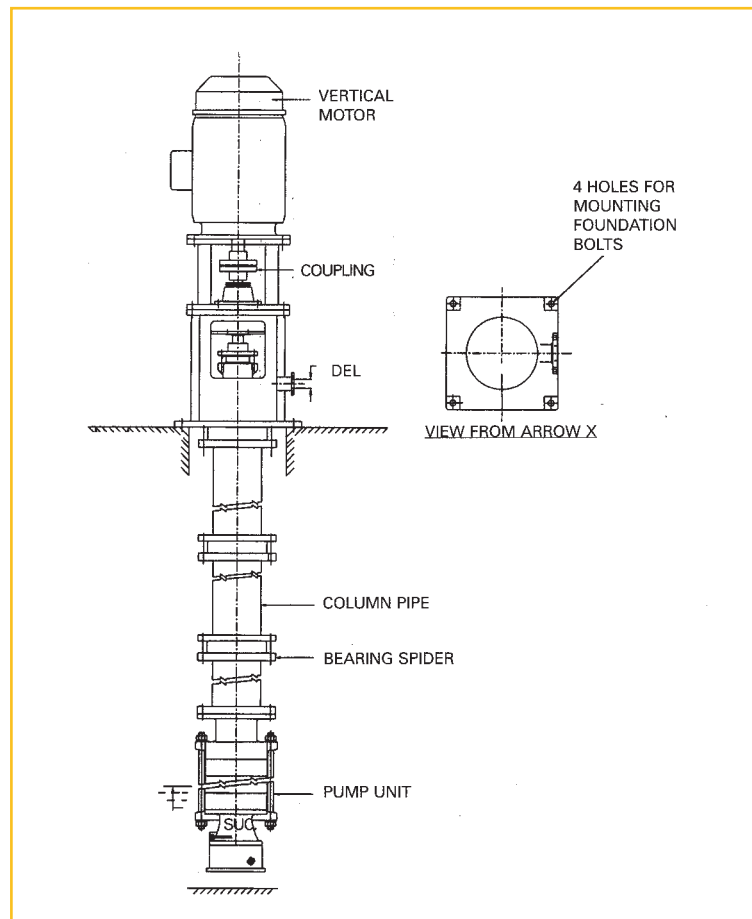

Vertical turbine type arrangement to save floor space

PERFORMANCE CHARACTERISTICS

Family Curves of multistage pumps at 1450 rpm - 50 Hz

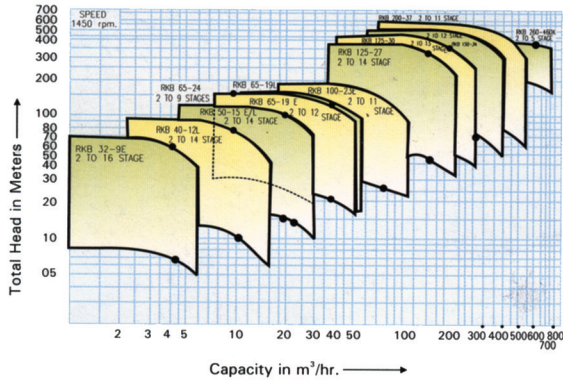

Family Curves of multistage pumps at 2900 rpm - 50 Hz

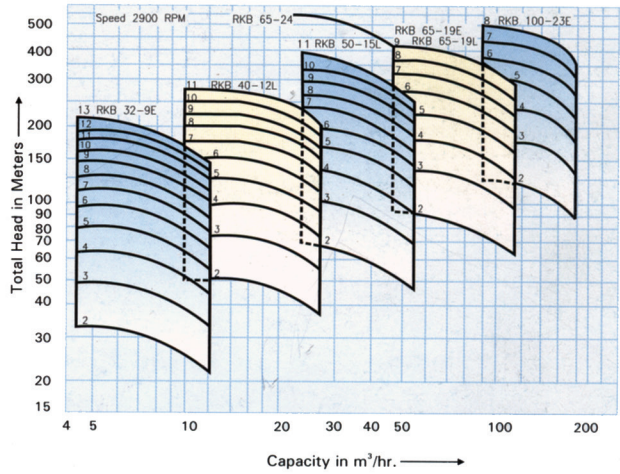

Family Curves of multistage pumps at 1750 rpm - 60 Hz

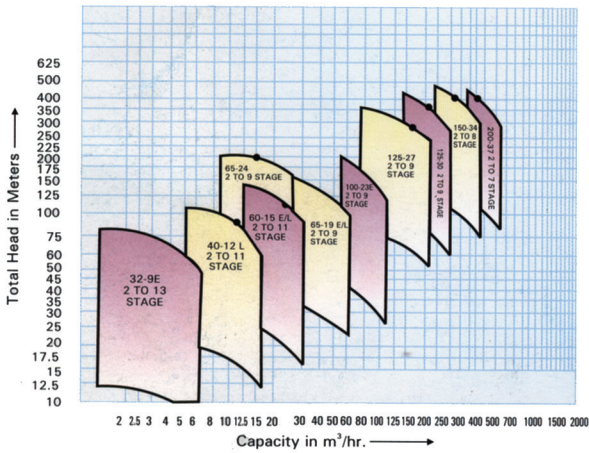

Family Curves of multistage pumps at 3500 rpm - 60 Hz

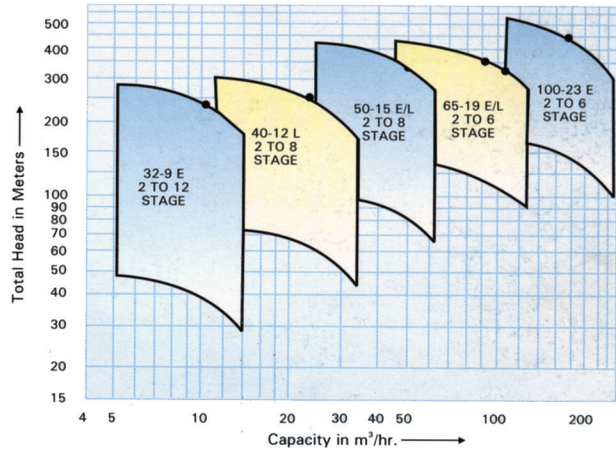

As we are constantly endeavouring to improve the performance of our products/equipment, we reserve the right to make alterations from time to time and as such our product equipment may differ from that detailed in this publication. For latest information you may get in touch with our Regional Sales Offices.

