

SOLIDS HANDLING NON CLOG PUMPS
TYPE : SHM / SHS / SHV

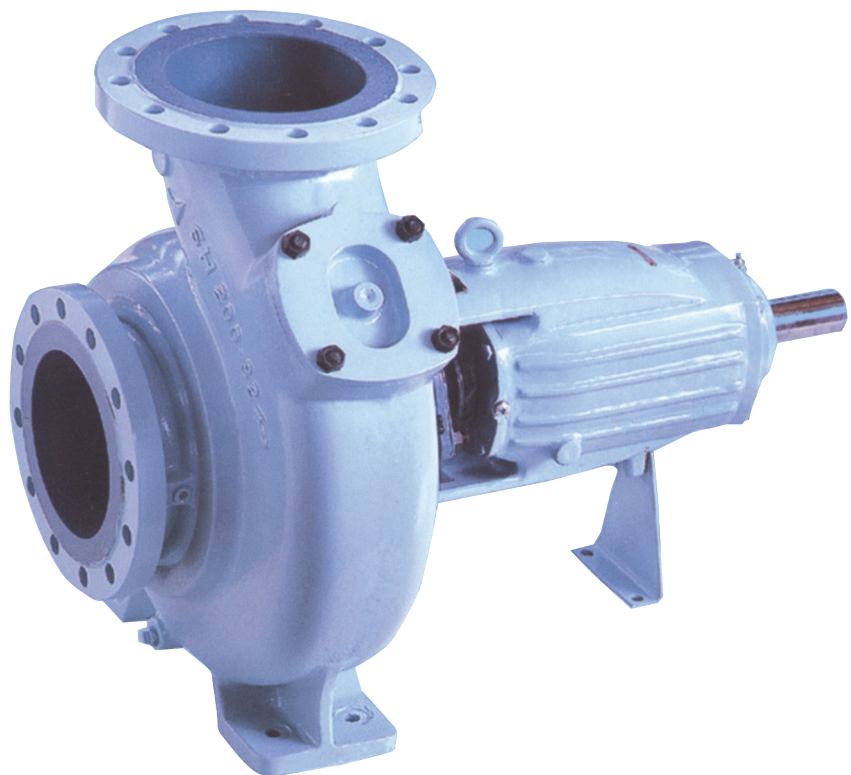

SOLID HANDLING NON CLOG PUMPS - TYPE SHM / SHS / SHV

Description

Range :

Delivery size upto 200mm
 Capacity up to 800 m³/hr
 Head up to 90 m
 Max. permissible solid size up to 105 mm, depending on the model
 Consistency upto 5%
 QP impellers for more than 5% consistency

Applications :

for handling liquids with solids in suspension, sludges or pulpy material in paper industries, sewage or waste with soft solids in suspension, viscous liquids or liquids carrying fibrous material or powdered material slurries, contaminated process liquids like sugar factory waste, trade liquors, water carrying gravel, etc.,

Constructional Features :

SHM are horizontal non clog pumps having single stage, single suction with back pull out type design. SHS are vertical nonclog pumps for wet pit applications. The pump unit is suspended by a column pipe which also protect the transmission shaft. These pump can be offered with a column length up to 6.5m.

SHV are vertical non log pumps for dry pit application in vertical orientation to be driven by vertical flange mounted motor which is directly coupled.

Also SHVT pumps are vertical non clog pumps for dry pit application in vertical orientation to be driven by vertical flange mounted motor which is directly coupled.

Also, SHVT pumps are vertical non clog pumps for dry vertical flange mounted motor but coupled through transmission shafting.

These pumps operate at 50 Hz and 60 Hz

Casing :

End suction with top centreline delivery as well as horizontal side delivery. High efficiency volute providing smooth unobstructed flow. Delivery flange and feet are cast integral with the casing. A large inspection opening is provided on

casing with easily removable cover.

Impeller :

Single suction type non clog impeller dynamically balanced. Enclosed or semi-open impellers are available in code N, P, Q or R.

Shaft :

in SHM pumps, four driving units cover the entire range. Shaft is supported by two bearings, Shaft in stuffing box area is protected by a shaft sleeve. Axial clearance between semi-open impeller and suction wear plate can be adjusted externally without dismantling the pump. The shaft sleeves under bearing housing and bearing spider are shrunk fitted to shaft in SHS pumps.

Stuffing Box :

Standard stuffing box is gland packed with grease sealing. Without cooling up to 90°C and with cooling upto 140°C.

Mechanical seal option is also available.

Bearings :

SHM Pumps
 Standard : Deep groove ball bearings at DE/NDE.

Optional :

- 1) Deep groove ball bearing at DE and roller bearing at NDE.
- 2) A pair of angular contact ball bearing (BECB) at DE & one cylindrical roller bearing at NDE

Standard lubrication is grease and optional is oil.

SHS pumps :

Intermediate shaft bearing is rubber (for water Lubrication) and bronze bearing (for grease lubrication). Thrust ball bearing in combination with metallic journal bearing at head shaft. Transmission bearings are lubricated with external clear water or grease.

Thrust bearings are grease lubricated.

Direction of Rotation :

Clockwise viewed from driving end.

Drive :

These pumps are suitable for coupling with electric motor or engine directly or through belt drives.

Flanges :

Standard drilling to DIN 2533 ND 16
 Optional drilling to ASA/BS/IS

CUT-SECTIONAL VIEW

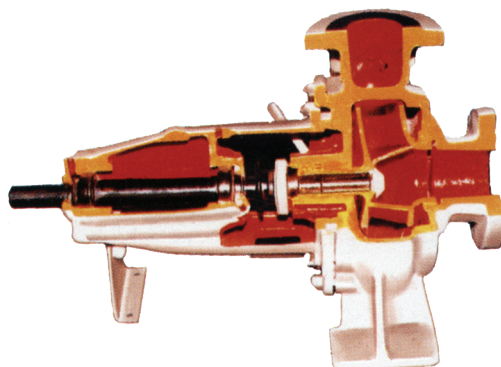

GENERAL DIMENSION & MOUNTING DETAILS

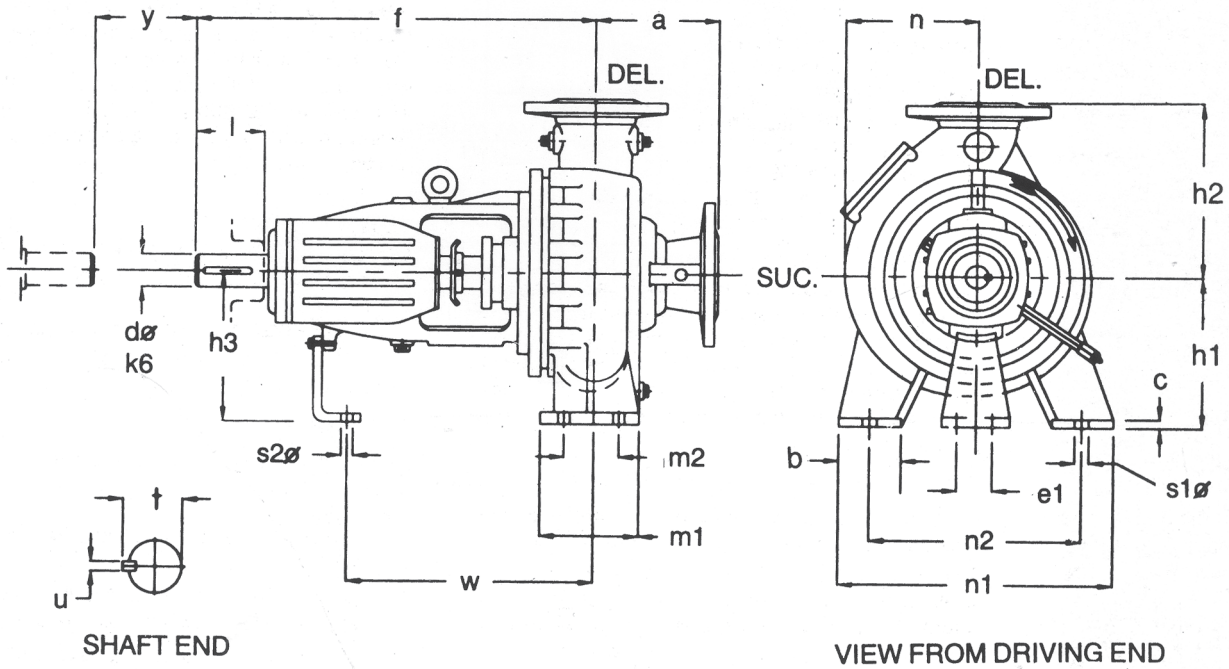

Typical Drawing

DIMENSIONS

PUMP	DRIVING	SUC ϕ	DEL ϕ	PUMP DIMENSIONS				FOOT DIMENSIONS										SHAFT END					NET WT. OF				
				a	f	h1	h2	n	b	c	m1	m2	n1	n2	s_{ϕ}^1	s_{ϕ}^1	e1	w	h3	d ϕ	l	t		u	y		
SHM 50/26	SHM7	65	50	150		200	250	180	65		135	95	320	250	14			200								100	
SHM 50/26 NB																											
SHM 65/32		80	65		570	225	280	210		18						15	110	400		225	32	80	35	10	140	126	
SHM 65/32 NB				180					80		160	120	400	315	18												
SHM 80/26		100	80			200	250	195										200								120	
SHM 100/26	SHM9	125	100			225	280	217				80														140	
SHM 100/32				180	630	250	315	237	80				400	315											140	165	
SHM 80/40		100	80					253		18	160				18	15	110		225	42	80	45	12			168	
SHM 150/26 NB		150	150	200	640		280	355				90	450	355				410							180	140	
SHM 100/40	SHM11	125	100	180			355																			200	
SHM 150/26						280		270																		170	
SHM 150/32		150	150		710			265	100		160	90	450	355	18	15	110	450	280	50	110	55.5	14	180		210	
SHM 150/40				200				315	296																		230
SHM 200/32		200	200					329		20																	300
SHM 150/50	SHM13	150	150			330	450	343		22			560	460												325	
SHM 200/40		200	200	225	885	320	400	302		20	200	130		500	400	18	15	110	650	330	60	110	63.2	18	180	350	

Note : 1) All dimensions are in mm unless otherwise specified.
2) Dimensions for oil and grease lubricated pumps are common.



SHS PUMP

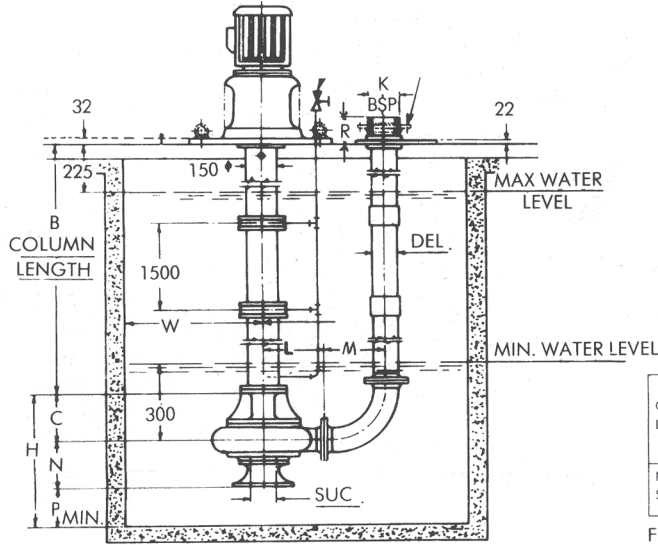

B COLUMN LENGTH	STD. OR	1M. 1.5M. (BELOW 2 METRE)	2M. 2.5M. 3M. (2M & BELOW 3.5M)	3.5M. 4M. 4.5M. (3.5M & BELOW 5M)	5M. 5.5M. 6M. (5M & UP TO 6M)
NO. OF BEARING SPIDER		NIL	1	2	3

For column length exceeding 6M contact us.

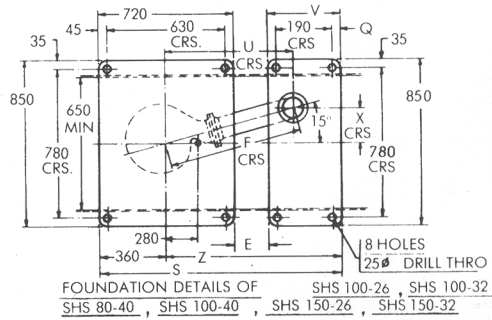
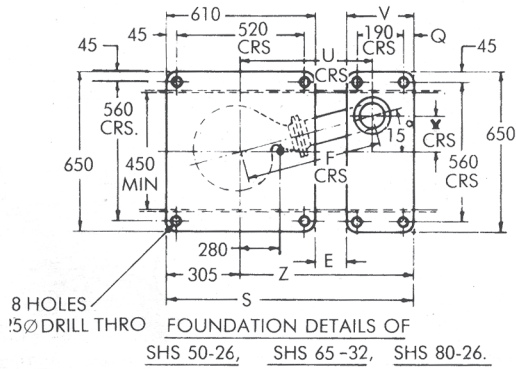

Typical Drawing

DIMENSIONS

PUMP MODEL	SUC	DEL	H	C	E	F	L	M	N	P	S	W MIN	Z	X	R	K BSP	U	Q	V	WT. KG.
SHS 50-26	65	50	535	175	15	492	251	241	202	158	875	550	570	127	103	2"	476	30	250	285
SHS 65-32	80	65	575	175	59	573	281	292	234	166	919	600	614	148	115	2.1/2"	554	30	250	315
SHS 80-26	100	80	610	175	80	581	251	330	233	202	940	600	635	150	115	3"	561	30	250	305
SHS 100-26	125	100	635	190	6	459	281	178	238	207	976	650	616	119	141	4"	444	30	250	460
SHS 100-32	125	100	635	190	30	494	316	178	238	207	1000	650	640	128	141	4"	477	30	250	470
SHS 80-40	100	80	610	190	180	686	356	330	218	202	1150	600	790	178	115	3"	663	30	250	450
SHS 100-40	124	100	650	200	30	534	356	178	238	212	1000	650	640	138	141	4"	516	30	250	506
SHS 150-26	150	150	675	200	79	584	356	228	258	217	1049	800	689	151	104	6"	564	30	250	505
SHS 150-32	150	150	670	200	122	629	401	228	258	217	1092	800	732	163	104	6"	607	30	250	515
SHS 150-40	150	150	675	200	79	584	356	228	258	217	1049	800	689	151	104	6"	564	30	250	530
SHS 200-32	200	200	675	200	79	584	356	228	258	217	1049	800	689	151	104	6"	564	30	250	565

All dimensions are in mm unless specified otherwise.
Weight are for pump with 1 m. column length



CROSS SECTIONA VIEW SHM PUMP

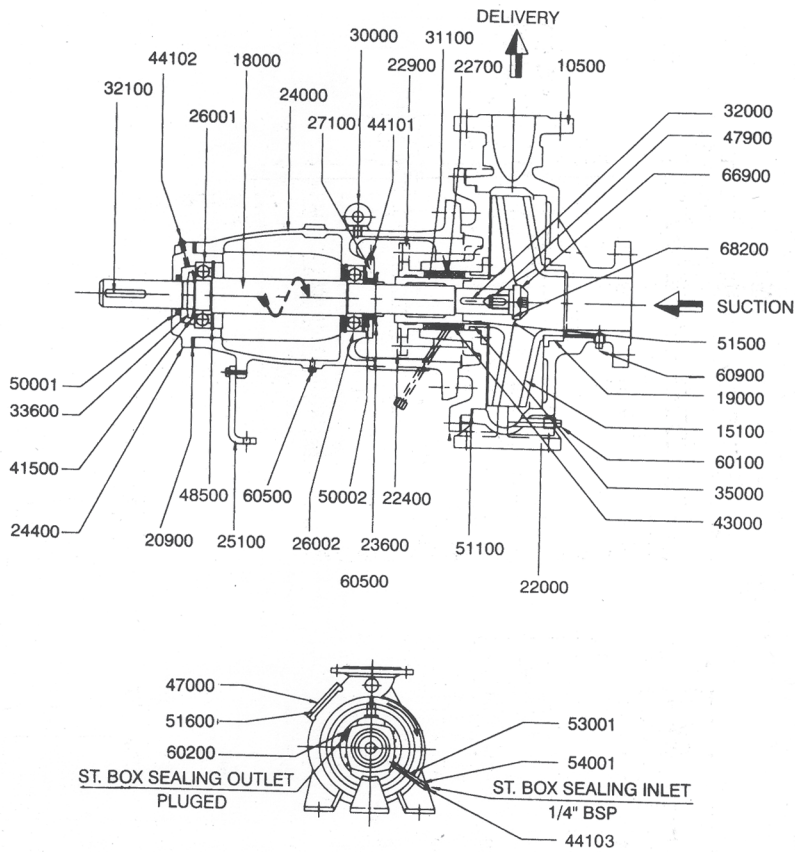

Typical Drawing

INTERCHANGEABILITY OF COMPONENTS

PART NO	NAME OF PART	TOTAL NO. OF PARTS	50/26	50/26B	80/26	65/32	65/32B	100/26	100/32	80/40	150/26B	150/26	150/32	200/32	100/40	150/40	200/40	150/50
			SHM-7				SHM-9				SHM-11				SHM-13			
10500	PUMP CASING	13	1	1	2	3	3	4	5	6	7	7	8	9	10	11	12	13
15100	IMPELLER	16	1	2	3	4	5	6	7	8	9	10	11	12	13	14	15	16
18000	SHAFT	4	1	1	1	1	1	2	2	2	2	3	3	3	3	3	4	4
19000	CASING RING	8	1	1	2	3	3	4	4	2	5	5	5	6	4	5	7	8
22000	CASING COVER	10	1	1	1	2	2	3	4	5	3	6	7	7	8	8	9	10
22700	LANTERN RING	4	1	1	1	1	1	2	2	2	2	3	3	3	3	3	4	4
22900	GLAND	4	1	1	1	1	1	2	2	2	2	3	3	3	3	3	4	4
23600	DEFLECTOR	4	1	1	1	1	1	2	2	2	2	3	3	3	3	3	4	4
24000	BEARING HOUSING	4	1	1	1	1	1	2	2	2	2	3	3	3	3	3	4	4
24100	CARTRIDGE	4	1	1	1	1	1	2	2	2	2	3	3	3	3	3	4	4
25100	SUPPORT FOOT	2	1	1	1	2	2	-	-	-	-	-	-	-	-	-	-	-
26001	BEARING NDE	4	1	1	1	1	1	2	2	2	2	3	3	3	3	3	4	4
26002	BEARING DE.	4	1	1	1	1	1	2	2	2	2	3	3	3	3	3	4	4
27100	BEARING COVER	4	1	1	1	1	1	2	2	2	2	3	3	3	3	3	4	4
31100	SHAFT SLEEVE	4	1	1	1	1	1	2	2	2	2	3	3	3	3	3	4	4
32000	IMPELLER KEY	4	1	1	1	1	1	2	2	2	2	3	3	3	3	3	4	4
32100	COUPLING KEY	4	1	1	1	1	1	2	2	2	2	3	3	3	3	3	4	4
35000	STUFFING BOX BUSH	4	1	1	1	1	1	2	2	2	2	3	3	3	3	3	4	4
47000	INSPECTION HOLE COVER	3	1	1	1	1	1	2	2	1	3	3	3	3	2	3	3	3



SHM PUMP

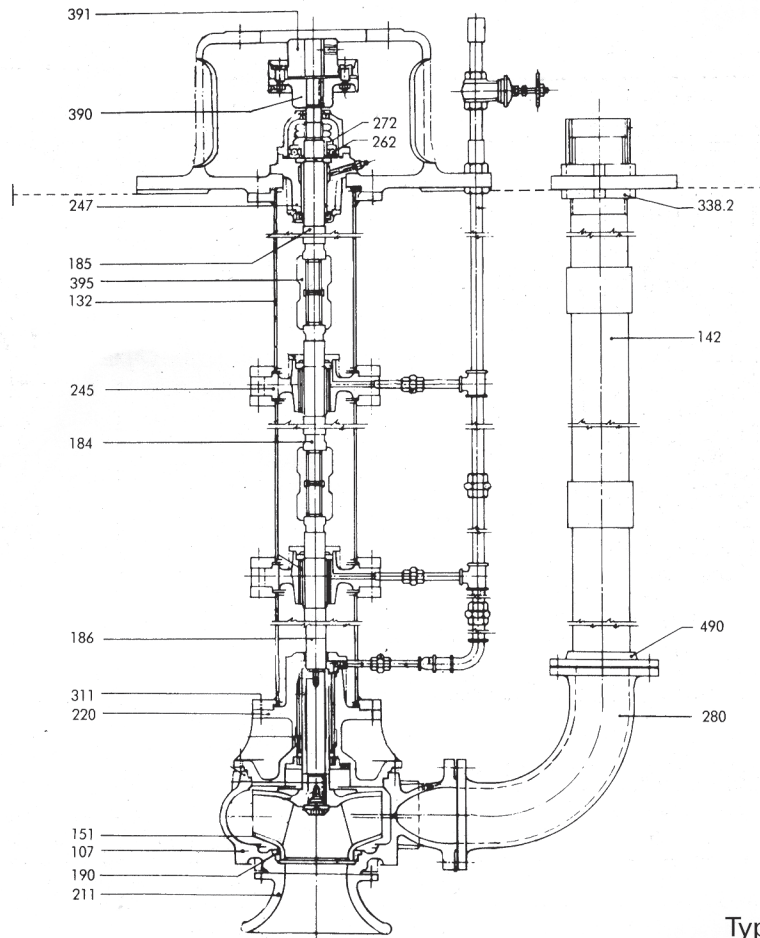

Typical Drawing

INTERCHANGEABILITY OF COMPONENTS

Part	NAME OF PART	TOTAL NO OF PARTS	PUMP MODEL										
			50/26	65/32	80/26	100/26	100/32	80/40	150/26	150/32	200/32	100/40	150/40
107	PUMP CASING	11	1	2	3	4	5	6	7	8	9	10	11
132	TOP COLUMN PIPE	2	1	1	1	1	1	1	1	1	2	1	2
142	RISING PIPES	5	1	2	3	4	4	3	5	5	5	4	5
151	IMPELLER	11	1	2	3	4	5	6	7	8	9	10	11
184	INTERMEDIATE SHAFT	1	1	1	1	1	1	1	1	1	1	1	1
185	HEAD SHAFT	2	1	1	1	1	1	1	1	1	2	1	2
186	PUMP SHAFT	3	1	1	1	2	2	2	3	3	3	3	3
190	CASING RING	6	1	3	2	4	4	2	5	5	5	4	6
211	SUCTION BELL MOUTH	6	1	3	2	4	4	2	5	5	5	4	6
220	CASING COVER	3	1	2	1	1	2	3	1	2	2	3	3
245	BEARING SPIDER	1	1	1	1	1	1	1	1	1	1	1	1
247	THRUST BEARING HOUSING	2	1	1	1	1	1	1	1	1	12	1	2
262	THRUST BALL BEARING	2	1	1	1	1	1	1	1	1	2	1	2
272	THRUST BEARING ADAPTER	2	1	1	1	1	1	1	1	1	2	1	2
280	BEND	5	1	2	3	4	4	3	5	5	5	4	5
311	IMPELLER SHAFT SLEEVE	3	1	1	1	2	2	2	3	3	3	3	3
338.2	PIPE NUT FOR RISING PIPE	5	1	2	3	4	4	3	5	5	5	4	5
390	COUPLING	TO SUIT MOTOR KW AND FRAME											
391													
395	SCREWED COUPLING												
490	COMPANION FLANGE	5	1	2	3	4	4	3	5	5	5	4	5

ALTERNATIVES AVAILABLE
TYPES OF IMPELLER

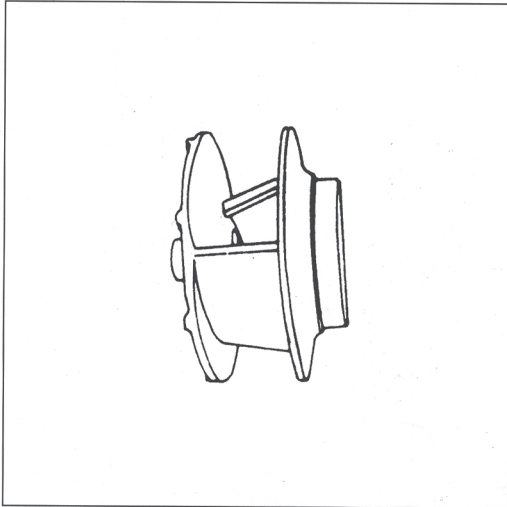

Two Vane enclosed impeller
Code - N

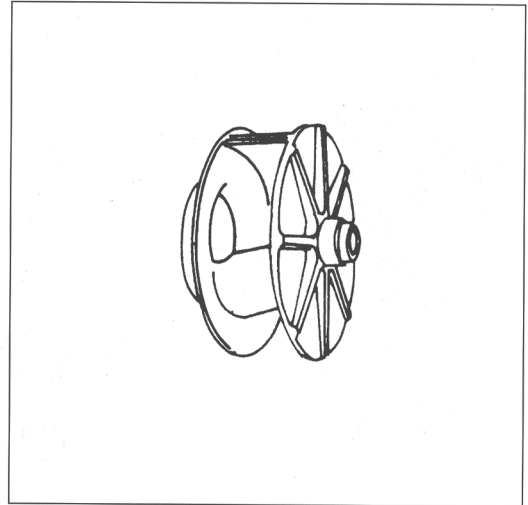

Single Vane enclosed impeller
Code - P

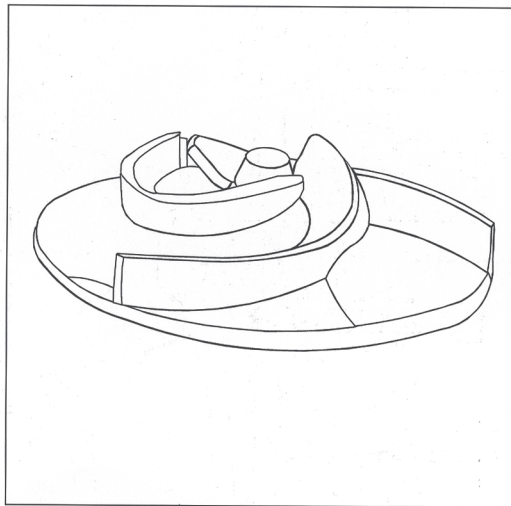

Three Vane semi-open impeller for higher consistency pump
Code - QP

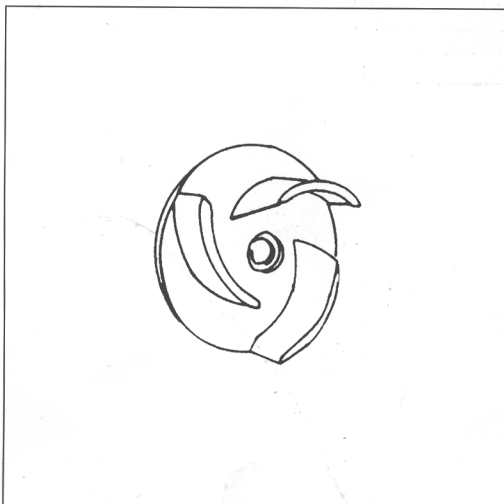

Three Vane semi-open impeller
Code - Q

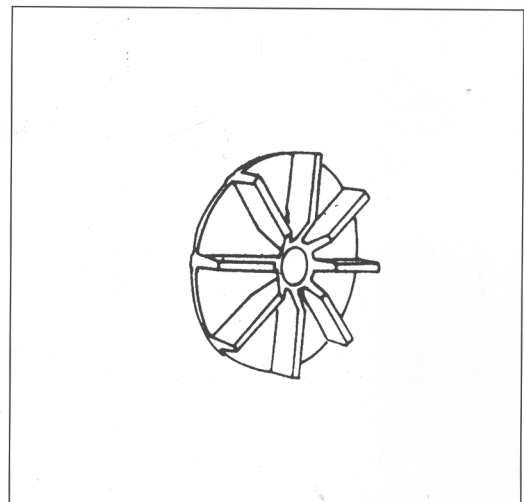

Free Flow impeller
Code - R

STUFFING BOX COOLING ARRANGEMENT

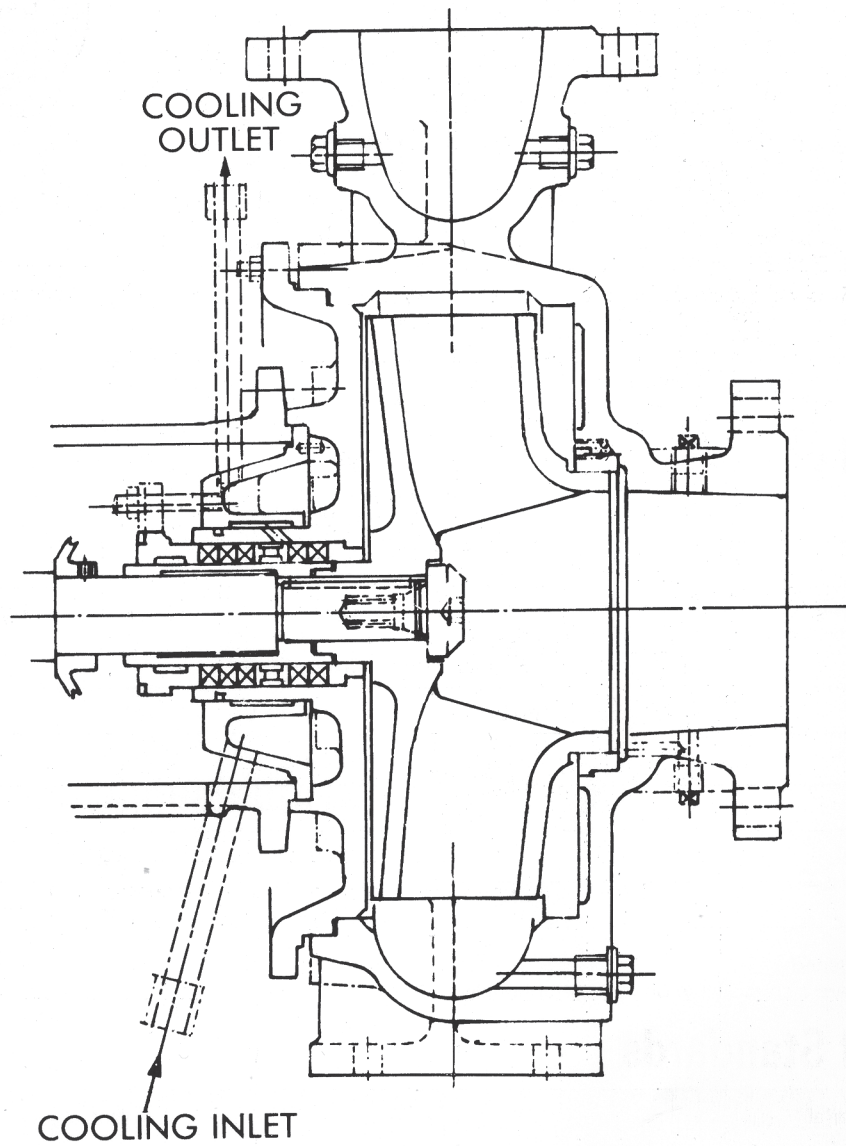

ALTERNATIVES AVAILABLE VERTICAL DRY PIT

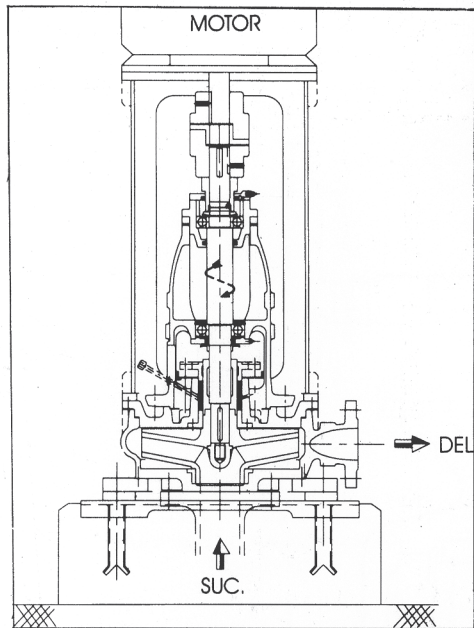

HORIZONTAL DELIVERY END

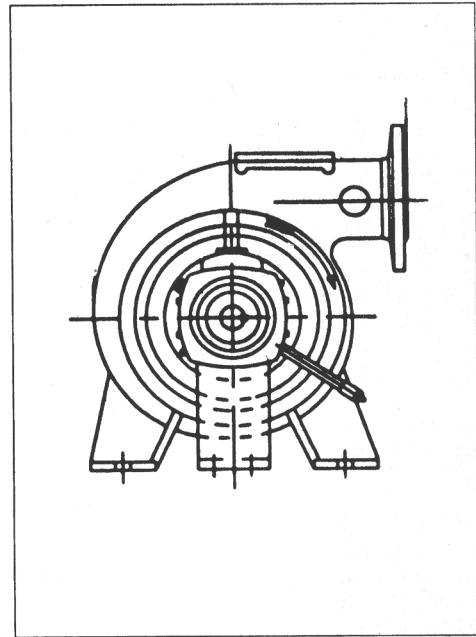

MATERIAL OF CONSTRUCTION :

	CI	CI	Bronze/PH.Br.	ACI	CF8M	Cast Steel
Pump Casing	CI	CI	Bronze/PH.Br.	ACI	CF8M	Cast Steel
Wear Plate	CI	CI	Bronze/PH.Br.	ACI	CF8M	Cast Steel
Casing Cover	CI	CI	Bronze/PH.Br.	ACI	CF8M	Cast Steel
Impeller	CI/Bronze	Ph. Br.	Bronze/PH.Br.	ACI	CF8M	Cast Steel
Wear Ring	CI/Bronze	Ph. Br.	Bronze/PH.Br.	ACI	CF8M	Cast Steel
Shaft	CS	CS	AISI 410	AISI 410	AISI 316	CS
Shaft Sleeve	AISI 410 (H)	AISI 410 (H)	AISI 410 (H)	AISI 410 (H)	AISI 316	AISI 410 H
Lantern Ring	CI	CI	CF8M	CF8M	CF8M	CF8M
Gland	CI	CI	CF8M	CF8M	CF8M	CF8M

(H) DENOTES HERDENED
OTHER MATERIALS ARE ALSO AVAILABLE ON REQUEST OPTIONALLY.

MATERIAL STANDARDS

MATERIAL	IS	EQUIVALENT INTERNATIONAL STANDARDS	
		BS	ASTM
Cast Iron (CI)	IS 210 Gr. FG 260	B.S 1452 Gr. 250	ASTM-A 48 CL35
Austenitic Cast Iron (ACI)	IS 2749 Gr. AGF Ni 15 Cu 6 Cr 3	B.S. 3468 AUS 101 Gr. B	ASTM-A 436 Type 1
Carbon Steel (CS)	IS 1570 Gr. 40 C 8	B.S. 970080 M 40	ASTM-A 107 Gr. 1040
CF8M	IS 3444 Gr. 9	B.S. 1632 Gr. B	ASTM-A 351 Gr. CF8M
AISI 316	IS 1570 Gr. 05 Cr 18 Ni 11 Mo 3	B.S. 970316 S 16	ASTM-A 276 Type 316
AISI 410		B.S. 970410 S 21	ASTM-A 276 Type 410
Bronze	IS 318 Gr. LTB 2	B.S. 1400 LG 2C	ASTM-B 62, B 145 Alloy 4A
Phosphor Bronze (Ph. Br.)	IS 28 Gr. 1	B.S. 1400 PB4	
Zinc Free Bronze		B.S. 1400 Gr. CT1	
Cast Steel		B.S. 1504101 A	ASTM-A216 Gr. 74d WCB

Family Curve of SHM/SHS/SHV/SHVT Pumps at 1450 rpm - 50 Hz.

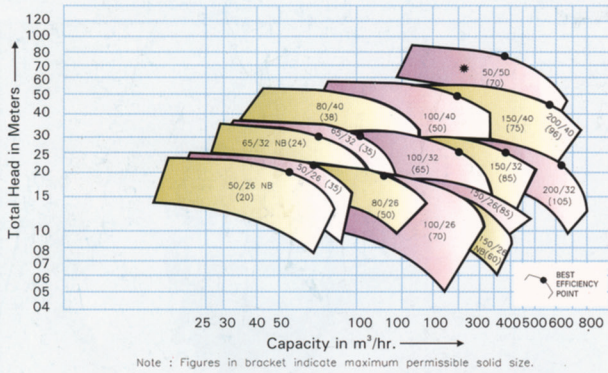

* Not applicable for SHS Pump

Family Curve of SHM/SHS/SHV/SHVT Pumps at 980 rpm - 50 Hz.

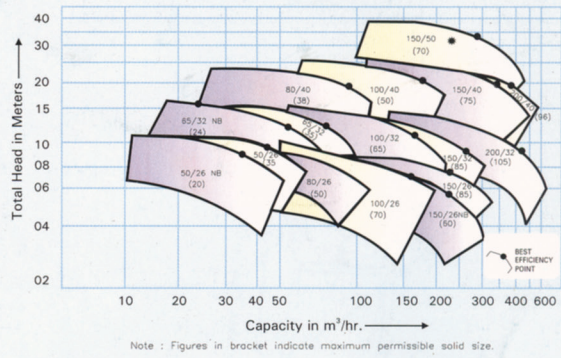

* Not applicable for SHS Pump

Family Curve of SHM/SHS/SHV/SHVT Pumps at 1150 rpm - 60 Hz.

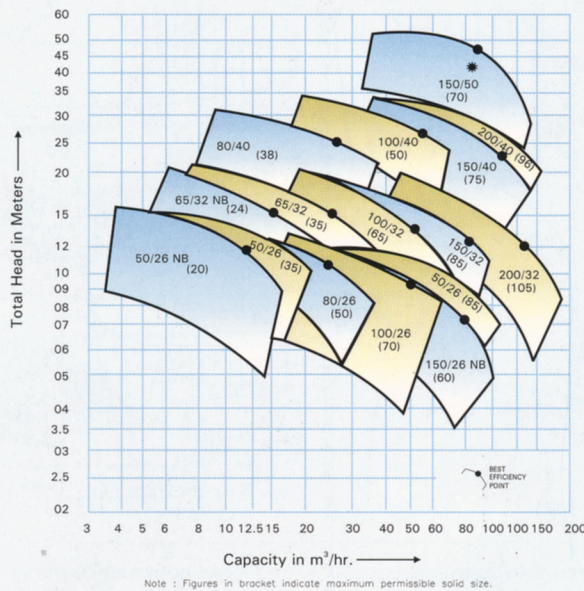

* Not applicable for SHS Pump

As we are constantly endeavouring to improve the performance of our products/equipment, we reserve the right to make alterations from time to time and as such our product equipment may differ from that detailed in this publication. For latest information you may get in touch with our Regional Sales Offices.

